

# Dir En Grey - Aoi Tsuki

♩ = 151,000381

Shinya  
Kaoru  
Die  
Toshiya  
Kyo

4

Shinya  
Toshiya

6

Shinya  
Kaoru  
Die  
Toshiya

7

Shinya  
Kaoru  
Die  
Toshiya

This system contains measures 7 and 8. Shinya's part is on a tenor staff with a key signature of one sharp (F#) and a common time signature. It features a sequence of notes: G4, A4, B4, C5, B4, A4, G4, F#4, E4, D4, C4. Kaoru's part is on a treble staff with a key signature of one sharp and a common time signature, containing eighth notes: G4, A4, B4, C5, B4, A4, G4, F#4, E4, D4, C4. Die's part is on a treble staff with a key signature of one sharp, showing a series of chords: G4, A4, B4, C5, B4, A4, G4, F#4, E4, D4, C4. Toshiya's part is on a bass staff with a key signature of one sharp, containing notes: G3, A3, B3, C4, B3, A3, G3, F#3, E3, D3, C3.

8

Shinya  
Kaoru  
Die  
Toshiya

This system contains measures 8 and 9. Shinya's part is on a tenor staff with a key signature of one sharp and a common time signature. It features a sequence of notes: G4, A4, B4, C5, B4, A4, G4, F#4, E4, D4, C4. Kaoru's part is on a treble staff with a key signature of one sharp and a common time signature, containing eighth notes: G4, A4, B4, C5, B4, A4, G4, F#4, E4, D4, C4. Die's part is on a treble staff with a key signature of one sharp, showing a series of chords: G4, A4, B4, C5, B4, A4, G4, F#4, E4, D4, C4. Toshiya's part is on a bass staff with a key signature of one sharp, containing notes: G3, A3, B3, C4, B3, A3, G3, F#3, E3, D3, C3.

9

Shinya  
Kaoru  
Die  
Toshiya

This system contains measures 9 and 10. Shinya's part is on a tenor staff with a key signature of one sharp and a common time signature. It features a sequence of notes: G4, A4, B4, C5, B4, A4, G4, F#4, E4, D4, C4. Kaoru's part is on a treble staff with a key signature of one sharp and a common time signature, containing eighth notes: G4, A4, B4, C5, B4, A4, G4, F#4, E4, D4, C4. Die's part is on a treble staff with a key signature of one sharp, showing a series of chords: G4, A4, B4, C5, B4, A4, G4, F#4, E4, D4, C4. Toshiya's part is on a bass staff with a key signature of one sharp, containing notes: G3, A3, B3, C4, B3, A3, G3, F#3, E3, D3, C3.

10

Shinya

Kaoru

Die

Toshiya

11

Shinya

Kaoru

Die

Toshiya

12

Shinya

Kaoru

Die

Toshiya

14

Shinya

Kaoru

Die

Toshiya

Kyo

16

Shinya

Kaoru

Die

Toshiya

17

Shinya

Kaoru

Die

Toshiya

18

Shinya

Kaoru

Die

Toshiya

Detailed description: This system contains measures 18 and 19. Shinya's part is a drum set with a snare line and a kick line. Kaoru's part is a vocal line with lyrics and a melodic line. Die's part is a guitar part with a treble clef, a key signature of one sharp (F#), and a series of chords. Toshiya's part is a bass line with a bass clef and a key signature of one sharp (F#).

19

Shinya

Kaoru

Die

Toshiya

Kyo

Detailed description: This system contains measures 19 and 20. Shinya's part is a drum set with a snare line and a kick line. Kaoru's part is a vocal line with lyrics and a melodic line. Die's part is a guitar part with a treble clef, a key signature of one sharp (F#), and a series of chords. Toshiya's part is a bass line with a bass clef and a key signature of one sharp (F#). Kyo's part is a piano line with a treble clef and a key signature of one sharp (F#).

20

Shinya

Kaoru

Die

Toshiya

Kyo

21

Shinya

Kaoru

Die

Toshiya

Kyo

23

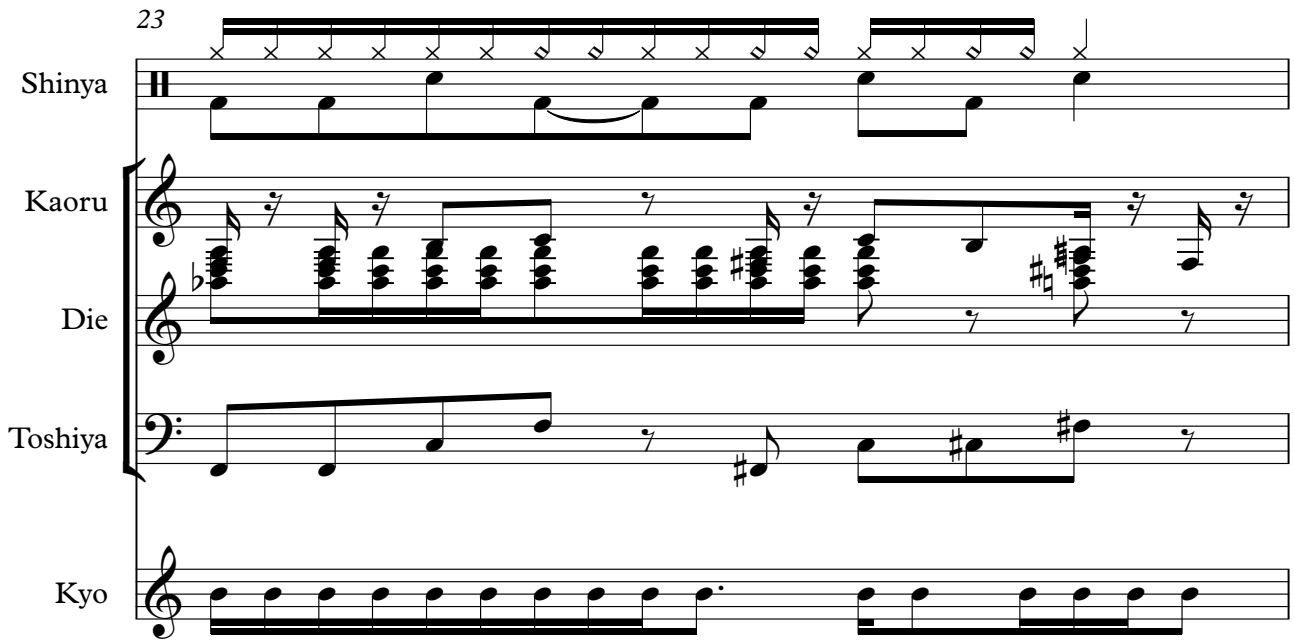

Shinya

Kaoru

Die

Toshiya

Kyo

Detailed description: This block contains the musical notation for measures 23 and 24. It features five staves: Shinya (drums) with a pattern of 'x' marks and notes; Kaoru (vocals) with a melodic line and lyrics; Die (guitar) with a complex chordal accompaniment; Toshiya (bass) with a bass line; and Kyo (piano) with a piano accompaniment. The score is written in a standard musical notation style with various clefs and time signatures.

24



Shinya

Kaoru

Die

Toshiya

Kyo

Detailed description: This block contains the musical notation for measures 24 and 25. It features five staves: Shinya (drums) with a pattern of 'x' marks and notes; Kaoru (vocals) with a melodic line and lyrics; Die (guitar) with a complex chordal accompaniment; Toshiya (bass) with a bass line; and Kyo (piano) with a piano accompaniment. The score is written in a standard musical notation style with various clefs and time signatures.

25

Shinya

Kaoru

Die

Toshiya

Kyo

Detailed description: This block contains the musical notation for measures 25 and 26. It features five staves: Shinya (drum), Kaoru (melody), Die (chords), Toshiya (bass), and Kyo (melody). Measure 25 shows a drum pattern with 'x' marks, a melodic line with eighth notes, a complex chordal accompaniment, a bass line with eighth notes, and a simple melodic line. Measure 26 continues these parts with similar rhythmic and melodic structures.

26

Shinya

Kaoru

Die

Toshiya

Kyo

Detailed description: This block contains the musical notation for measures 26 and 27. It features five staves: Shinya (drum), Kaoru (melody), Die (chords), Toshiya (bass), and Kyo (melody). Measure 26 shows a drum pattern with 'x' marks, a melodic line with eighth notes, a complex chordal accompaniment, a bass line with eighth notes, and a simple melodic line. Measure 27 continues these parts with similar rhythmic and melodic structures.



27

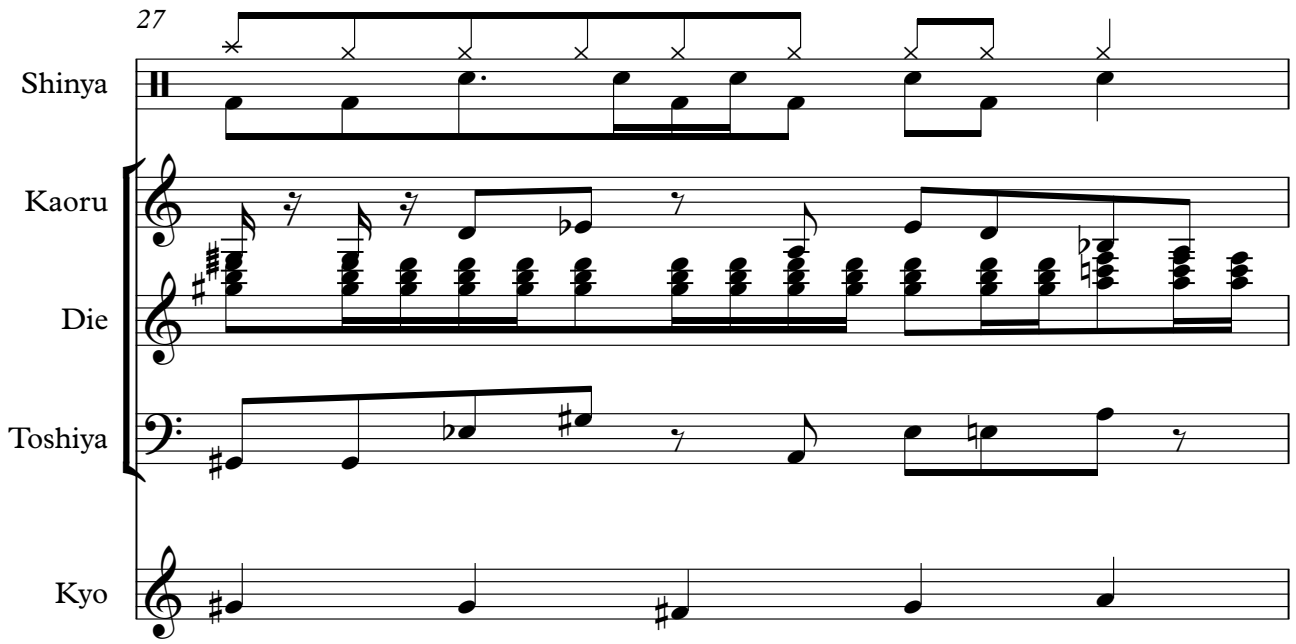

Shinya

Kaoru

Die

Toshiya

Kyo

Detailed description: This block contains the musical notation for measures 27 through 30. It features five staves. The top staff is for Shinya (drums), showing a pattern of eighth notes with 'x' marks above them. The second staff is for Kaoru (vocals), with a treble clef and a key signature of one sharp (F#). The third staff is for Die (guitar), with a treble clef and a key signature of one sharp, showing a series of chords. The fourth staff is for Toshiya (bass), with a bass clef and a key signature of one sharp. The bottom staff is for Kyo (piano), with a treble clef and a key signature of one sharp, showing a simple melodic line.

28



Shinya

Kaoru

Die

Toshiya

Kyo

Detailed description: This block contains the musical notation for measures 28 through 31. It features five staves. The top staff is for Shinya (drums), showing a pattern of eighth notes with 'x' marks above them. The second staff is for Kaoru (vocals), with a treble clef and a key signature of one sharp (F#). The third staff is for Die (guitar), with a treble clef and a key signature of one sharp, showing a series of chords. The fourth staff is for Toshiya (bass), with a bass clef and a key signature of one sharp. The bottom staff is for Kyo (piano), with a treble clef and a key signature of one sharp, showing a simple melodic line.

29

Shinya

Kaoru

Die

Toshiya

Kyo

30

Shinya

Kaoru

Die

Toshiya

Kyo

32

Shinya

Kaoru

Die

Toshiya

Kyo

34

Shinya

Kaoru

Die

Toshiya

Kyo

37

Shinya

Kaoru

Die

Toshiya

Kyo

40

Shinya

Kaoru

Die

Toshiya

Kyo

42

Shinya

Kaoru

Die

Toshiya

Kyo

45

Shinya

Kaoru

Toshiya

Kyo

48

Shinya

Kaoru

Die

Toshiya

Kyo

51

Shinya

Kaoru

Die

Toshiya

Kyo

53

Shinya

Kaoru

Die

Toshiya

Kyo

Detailed description: This block contains the musical notation for measures 53 and 54. It features five staves. The Shinya staff is a guitar tab with a treble clef and a key signature of one sharp (F#), showing a sequence of chords with 'x' marks above the notes. The Kaoru staff is a vocal line in treble clef with a key signature of one sharp, featuring a melodic line with many slurs and accents. The Die staff is a vocal line in treble clef with a key signature of one sharp, showing a more rhythmic accompaniment. The Toshiya staff is a vocal line in bass clef with a key signature of one sharp, providing a bass line. The Kyo staff is a vocal line in treble clef with a key signature of one sharp, showing a sparse melodic line.

55

Shinya

Kaoru

Die

Toshiya

Kyo

Detailed description: This block contains the musical notation for measures 55 and 56. It features five staves. The Shinya staff is a guitar tab with a treble clef and a key signature of one sharp, showing a sequence of chords with 'x' marks above the notes. The Kaoru staff is a vocal line in treble clef with a key signature of one sharp, featuring a melodic line with many slurs and accents. The Die staff is a vocal line in treble clef with a key signature of one sharp, showing a more rhythmic accompaniment. The Toshiya staff is a vocal line in bass clef with a key signature of one sharp, providing a bass line. The Kyo staff is a vocal line in treble clef with a key signature of one sharp, showing a sparse melodic line.

57

Shinya

Kaoru

Die

Toshiya

Kyo

59

Shinya

Kaoru

Die

Toshiya

Kyo



61

Shinya

Kaoru

Die

Toshiya

Kyo

Detailed description: This block contains the musical notation for measures 61 and 62. It features five staves. The top staff, labeled 'Shinya', is a guitar tab with a treble clef and a key signature of one sharp (F#), showing a sequence of chords with 'x' marks above the notes. The second staff, 'Kaoru', is a vocal line in treble clef with a key signature of one sharp, featuring a melodic line with many slurs and accents. The third staff, 'Die', is a piano accompaniment in treble clef with a key signature of one sharp, consisting of a steady eighth-note accompaniment. The fourth staff, 'Toshiya', is a piano accompaniment in bass clef with a key signature of one sharp, also featuring a steady eighth-note accompaniment. The fifth staff, 'Kyo', is a vocal line in treble clef with a key signature of one sharp, showing a simple melodic line.

63

Shinya

Kaoru

Die

Toshiya

Kyo

Detailed description: This block contains the musical notation for measures 63 and 64. It features five staves. The top staff, labeled 'Shinya', is a guitar tab with a treble clef and a key signature of one sharp, showing a sequence of chords with 'x' marks above the notes. The second staff, 'Kaoru', is a vocal line in treble clef with a key signature of one sharp, featuring a melodic line with many slurs and accents. The third staff, 'Die', is a piano accompaniment in treble clef with a key signature of one sharp, consisting of a steady eighth-note accompaniment. The fourth staff, 'Toshiya', is a piano accompaniment in bass clef with a key signature of one sharp, also featuring a steady eighth-note accompaniment. The fifth staff, 'Kyo', is a vocal line in treble clef with a key signature of one sharp, showing a simple melodic line.

65

Shinya

Kaoru

Die

Toshiya

Kyo

67

Shinya

Kaoru

Die

Toshiya

Kyo

69

Shinya  
Kaoru  
Die  
Toshiya  
Kyo

This musical system covers measures 69 and 70. It features five staves: Shinya (drums), Kaoru (guitar), Die (guitar), Toshiya (bass), and Kyo (guitar). Measure 69 shows a drum pattern with 'x' marks for cymbals and a bass line with eighth notes. Measure 70 introduces a key change to D major, indicated by a key signature change to two sharps (F# and C#), and features more complex guitar and bass parts.

71

Shinya  
Kaoru  
Die  
Toshiya  
Kyo

This musical system covers measures 71, 72, and 73. Measure 71 continues the drum and bass patterns. Measure 72 shows a key change to D minor, indicated by a key signature change to one flat (Bb), and features a guitar solo with various techniques like bends and vibrato. Measure 73 continues the instrumental arrangement with complex guitar and bass parts.

74

Shinya

Kaoru

Die

Toshiya

Kyo

Detailed description: This system of musical notation covers measures 74 and 75. It features five staves: Shinya (drum), Kaoru (melody), Die (chords), Toshiya (bass), and Kyo (melody). Measure 74 shows a drum pattern with 'x' marks above the staff, a melodic line in Kaoru, a complex chordal structure in Die, a bass line in Toshiya, and a simple melodic line in Kyo. Measure 75 continues these parts with some changes in the drum and chordal patterns.

76

Shinya

Kaoru

Die

Toshiya

Kyo

Detailed description: This system of musical notation covers measures 76 and 77. It features five staves: Shinya (drum), Kaoru (melody), Die (chords), Toshiya (bass), and Kyo (melody). Measure 76 shows a drum pattern with 'x' marks, a melodic line in Kaoru, a complex chordal structure in Die, a bass line in Toshiya, and a simple melodic line in Kyo. Measure 77 continues these parts with some changes in the drum and chordal patterns.

78

Shinya

Kaoru

Die

Toshiya

Kyo

80

Shinya

Kaoru

Die

Toshiya

Kyo

82

Shinya

Kaoru

Die

Toshiya

Kyo

83

Shinya

Kaoru

Die

Toshiya

Kyo

84

Shinya

Kaoru

Die

Toshiya

Detailed description: This block contains the musical notation for measures 84 and 85. It features four staves: Shinya (drum), Kaoru (melody), Die (chords), and Toshiya (bass). Measure 84 shows a drum pattern with 'x' marks above the staff, a melody line with eighth and quarter notes, a series of chords in the Die part, and a bass line with a rising eighth-note pattern. Measure 85 continues these parts with similar rhythmic and melodic elements.

85

Shinya

Kaoru

Die

Toshiya

Kyo

Detailed description: This block contains the musical notation for measures 85 and 86. It features five staves: Shinya (drum), Kaoru (melody), Die (chords), Toshiya (bass), and Kyo (melody). Measure 85 continues the drum, Kaoru, Die, and Toshiya parts from the previous block. Measure 86 introduces a new Kyo part with a simple melody of quarter notes. The other parts continue with similar rhythmic and melodic elements.

86

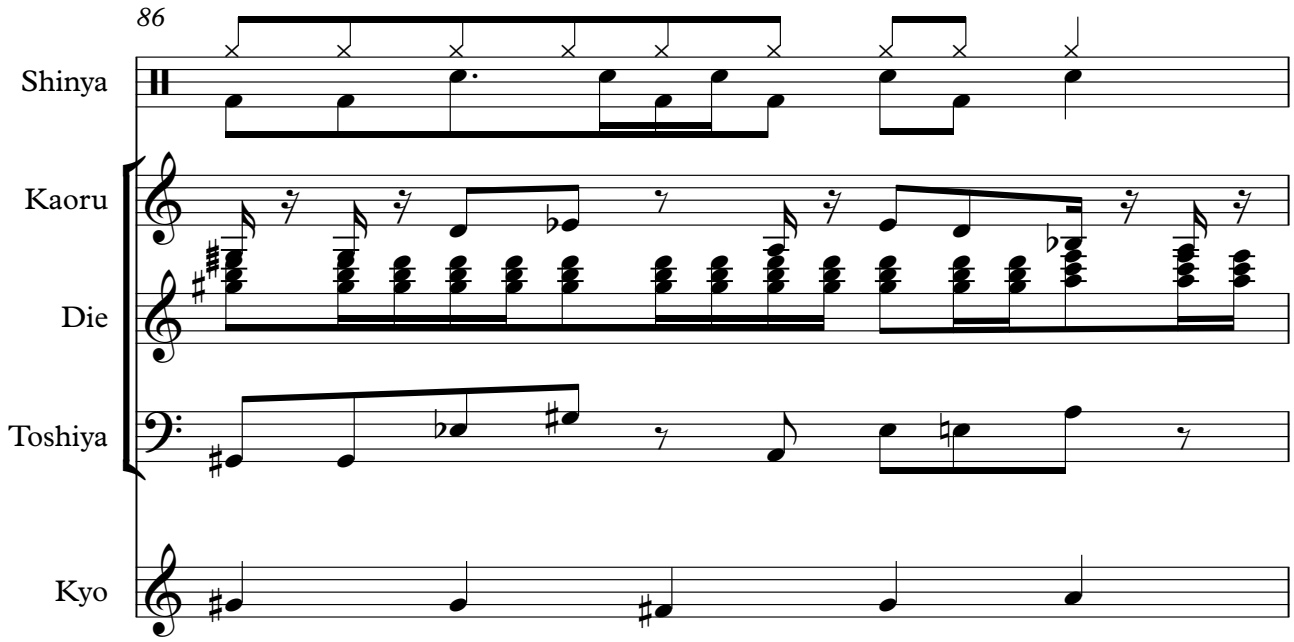

Shinya

Kaoru

Die

Toshiya

Kyo

Detailed description: This block contains the musical notation for measures 86 and 87. It features five staves: Shinya (guitar), Kaoru (vocals), Die (chords), Toshiya (bass), and Kyo (piano). The key signature has two sharps (F# and C#). The Shinya staff shows a guitar line with a bar line at the end of measure 86. The Kaoru staff has a vocal line with lyrics. The Die staff shows a series of chords. The Toshiya staff has a bass line. The Kyo staff has a piano accompaniment.

87



Shinya

Kaoru

Die

Toshiya

Kyo

Detailed description: This block contains the musical notation for measures 87 and 88. It features five staves: Shinya (guitar), Kaoru (vocals), Die (chords), Toshiya (bass), and Kyo (piano). The key signature has two sharps (F# and C#). The Shinya staff shows a guitar line with a bar line at the end of measure 87. The Kaoru staff has a vocal line with lyrics. The Die staff shows a series of chords. The Toshiya staff has a bass line. The Kyo staff has a piano accompaniment.



88

Shinya

Kaoru

Die

Toshiya

Kyo

89

Shinya

Kaoru

Die

Toshiya

Kyo

90



Shinya

Kaoru

Die

Toshiya

Kyo

Detailed description: This musical score block covers measures 90 and 91. It features five staves. The top staff, labeled 'Shinya', is a guitar part with a treble clef and a key signature of one flat, showing a series of chords and melodic lines. The second staff, 'Kaoru', is a vocal line with a treble clef and a key signature of one flat, containing lyrics and melodic notes. The third staff, 'Die', is a piano accompaniment with a treble clef and a key signature of one flat, featuring complex chordal textures. The fourth staff, 'Toshiya', is a bass line with a bass clef and a key signature of one flat, providing a steady harmonic foundation. The bottom staff, 'Kyo', is a guitar part with a treble clef and a key signature of one flat, playing a simple melodic line.

91



Shinya

Kaoru

Die

Toshiya

Kyo

Detailed description: This musical score block covers measures 91 and 92. It features five staves. The top staff, labeled 'Shinya', is a guitar part with a treble clef and a key signature of one flat, showing a series of chords and melodic lines. The second staff, 'Kaoru', is a vocal line with a treble clef and a key signature of one flat, containing lyrics and melodic notes. The third staff, 'Die', is a piano accompaniment with a treble clef and a key signature of one flat, featuring complex chordal textures. The fourth staff, 'Toshiya', is a bass line with a bass clef and a key signature of one flat, providing a steady harmonic foundation. The bottom staff, 'Kyo', is a guitar part with a treble clef and a key signature of one flat, playing a simple melodic line.

92

Shinya

Kaoru

Die

Toshiya

Kyo

93

Shinya

Kaoru

Die

Toshiya

Kyo

94

Shinya

Kaoru

Die

Toshiya

Kyo

95

Shinya

Kaoru

Die

Toshiya

Kyo

96

Shinya

Kaoru

Die

Toshiya

Kyo

Detailed description: This block contains the musical notation for measures 96 and 97. It features five staves: Shinya (guitar), Kaoru (piano), Die (piano), Toshiya (bass), and Kyo (piano). The key signature has one sharp (F#) and the time signature is 6/4. Measure 96 is marked with guitar fretting symbols (x) above the staff. Measure 97 is marked with a 4/4 time signature. The piano parts (Kaoru, Die, Kyo) feature complex chordal textures with many accidentals.

98

Shinya

Kaoru

Die

Toshiya

Kyo

Detailed description: This block contains the musical notation for measures 98, 99, and 100. It features the same five staves as the previous block. Measure 98 is marked with guitar fretting symbols (x) above the staff. Measure 99 is marked with a 4/4 time signature. The piano parts (Kaoru, Die, Kyo) continue with complex chordal textures and accidentals.

101

Shinya

Kaoru

Die

Toshiya

Kyo

104

Shinya

Kaoru

Die

Toshiya

Kyo

106

Shinya

Kaoru

Die

Toshiya

Kyo

108

Shinya

Kaoru

Die

Toshiya

Kyo

111

Shinya

Kaoru

Toshiya

Kyo

114

Shinya

Kaoru

Die

Toshiya

Kyo



117

Shinya

Kaoru

Die

Toshiya

Kyo

119

Shinya

Kaoru

Die

Toshiya

Kyo

121

Shinya

Kaoru

Die

Toshiya

Kyo

123

Shinya

Kaoru

Die

Toshiya

Kyo

125

Shinya

Kaoru

Die

Toshiya

Kyo

127

Shinya

Kaoru

Die

Toshiya

Kyo

129

Shinya

Kaoru

Die

Toshiya

Kyo

132

Shinya

Kaoru

Die

Toshiya

Kyo

134

Shinya

Kaoru

Die

Toshiya

Kyo

136

Shinya

Kaoru

Die

Toshiya

Kyo

138

Shinya

Kaoru

Die

Toshiya

Kyo

140

Shinya

Kaoru

Die

Toshiya

Kyo

142

Shinya  
Kaoru  
Die  
Toshiya  
Kyo

This musical system covers measures 142 and 143. It features five staves: Shinya (guitar), Kaoru (treble clef), Die (treble clef), Toshiya (bass clef), and Kyo (treble clef). The key signature has one flat (B-flat). Measure 142 shows a guitar part with a series of 'x' marks above the staff, indicating muted notes. The other instruments play a melodic line with eighth and sixteenth notes. Measure 143 continues the melodic development with some chromatic movement.

144

Shinya  
Kaoru  
Die  
Toshiya  
Kyo

This musical system covers measures 144 and 145. It features the same five staves as the previous system. Measure 144 continues the guitar part with muted notes and the melodic line. Measure 145 shows a continuation of the melodic line, with some chromatic movement and a key change to two flats (B-flat and E-flat) in the final measure.

146

Shinya

Kaoru

Die

Toshiya

Kyo

149

Shinya

Kaoru

Die

Toshiya

Kyo



151

Shinya

Kaoru

Die

Toshiya

Kyo

Detailed description: This system of musical notation covers measures 151 and 152. It features five staves: Shinya (drum), Kaoru (melody), Die (chords), Toshiya (bass), and Kyo (melody). The key signature has two sharps (F# and C#). The drum part (Shinya) shows a consistent rhythmic pattern with 'x' marks above the notes. The Kaoru staff has a melodic line with slurs and accents. The Die staff provides harmonic support with chords and some bass notes. The Toshiya staff has a bass line with a few accidentals. The Kyo staff has a simple melodic line.

153

Shinya

Kaoru

Die

Toshiya

Kyo

Detailed description: This system of musical notation covers measures 153 and 154. It features the same five staves as the previous system. The drum part (Shinya) continues with its rhythmic pattern. The Kaoru staff has a more complex melodic line with many slurs and accents. The Die staff has dense chordal textures. The Toshiya staff has a bass line with several accidentals. The Kyo staff has a melodic line with some accidentals.

155

Shinya

Kaoru

Die

Toshiya

Kyo

Detailed description: This system of music covers measures 155 and 156. It features five staves: Shinya (guitar), Kaoru (melody), Die (chords), Toshiya (bass), and Kyo (melody). The key signature has one sharp (F#) and the time signature is 5/4. Measure 155 shows a guitar part with a series of 'x' marks above the staff, indicating muted notes. The other parts have various rhythmic patterns, including eighth and quarter notes. Measure 156 continues these patterns with some changes in the guitar and bass lines.

157

Shinya

Kaoru

Die

Toshiya

Kyo

Detailed description: This system of music covers measures 157 and 158. It features the same five staves as the previous system. Measure 157 shows the guitar part with 'x' marks above the staff. The other parts continue their respective rhythmic and melodic lines. Measure 158 concludes the system with similar musical notation.

158

Shinya

Kaoru

Die

Toshiya

Kyo

159

Shinya

Kaoru

Die

Toshiya

Kyo

160

Shinya

Kaoru

Die

Toshiya

Kyo

161

Shinya

Kaoru

Die

Toshiya

Kyo

162

Shinya

Kaoru

Die

Toshiya

Kyo

Detailed description: This block contains the musical notation for measures 162 and 163. It features five staves: Shinya (drum), Kaoru (melody), Die (chords), Toshiya (bass), and Kyo (piano). Measure 162 shows a drum pattern with a snare on the first beat and a hi-hat on the second. The melody in Kaoru starts with a quarter note, followed by eighth notes. The Die part consists of a series of chords. Toshiya plays a bass line with a mix of quarter and eighth notes. Kyo has a simple piano accompaniment with quarter notes and rests.

163

Shinya

Kaoru

Die

Toshiya

Kyo

Detailed description: This block contains the musical notation for measures 163 and 164. It features five staves: Shinya (drum), Kaoru (melody), Die (chords), Toshiya (bass), and Kyo (piano). Measure 163 continues the drum pattern from the previous block. The melody in Kaoru continues with eighth notes. The Die part continues with chords. Toshiya continues with a bass line. Kyo continues with piano accompaniment. Measure 164 shows a change in the drum pattern, with a snare on the first beat and a hi-hat on the second. The melody in Kaoru continues with eighth notes. The Die part continues with chords. Toshiya continues with a bass line. Kyo continues with piano accompaniment.

164

Shinya

Kaoru

Die

Toshiya

Kyo

Detailed description: This block contains the musical notation for measures 164 and 165. It features five staves: Shinya (drum), Kaoru (melody), Die (chords), Toshiya (bass), and Kyo (bass). The key signature has one sharp (F#). The Shinya staff shows a drum pattern with asterisks and 'x' marks. The Kaoru staff has a melodic line with eighth and quarter notes. The Die staff shows a series of chords. The Toshiya and Kyo staves have bass lines with eighth and quarter notes.

165

Shinya

Kaoru

Die

Toshiya

Kyo

Detailed description: This block contains the musical notation for measures 165 and 166. It features five staves: Shinya (drum), Kaoru (melody), Die (chords), Toshiya (bass), and Kyo (bass). The key signature has one sharp (F#). The Shinya staff shows a drum pattern with asterisks and 'x' marks. The Kaoru staff has a melodic line with eighth and quarter notes. The Die staff shows a series of chords. The Toshiya and Kyo staves have bass lines with eighth and quarter notes.

166

Shinya

Kaoru

Die

Toshiya

Kyo

Detailed description: This block contains the musical notation for measures 166 and 167. It features five staves: Shinya (drum), Kaoru (melody), Die (chords), Toshiya (bass), and Kyo (bass). The key signature has one sharp (F#). The Shinya staff shows a drum pattern with asterisks and 'x' marks. The Kaoru staff has a melodic line with eighth and quarter notes. The Die staff shows a series of chords. The Toshiya and Kyo staves have bass lines with eighth and quarter notes.

167

Shinya

Kaoru

Die

Toshiya

Kyo

Detailed description: This block contains the musical notation for measures 167 and 168. It features five staves: Shinya (drum), Kaoru (melody), Die (chords), Toshiya (bass), and Kyo (bass). The key signature has one sharp (F#). The Shinya staff shows a drum pattern with asterisks and 'x' marks. The Kaoru staff has a melodic line with eighth and quarter notes. The Die staff shows a series of chords. The Toshiya and Kyo staves have bass lines with eighth and quarter notes.

168

Shinya

Kaoru

Die

Toshiya

Kyo

169

Shinya

Kaoru

Die

Toshiya

Kyo



170

Shinya

Kaoru

Die

Toshiya

Kyo

Detailed description: This system of musical notation covers measures 170 and 171. It features five staves: Shinya (drum), Kaoru (melody), Die (chords), Toshiya (bass), and Kyo (piano accompaniment). The key signature has one sharp (F#). The Shinya staff shows a complex drum pattern with asterisks marking specific hits. The Kaoru staff has a melodic line with various note values and rests. The Die staff consists of block chords. The Toshiya staff has a bass line with some chromatic movement. The Kyo staff provides a piano accompaniment with chords and rests.

171

Shinya

Kaoru

Die

Toshiya

Kyo

Detailed description: This system of musical notation covers measures 171 and 172. It features five staves: Shinya (drum), Kaoru (melody), Die (chords), Toshiya (bass), and Kyo (piano accompaniment). The key signature has one sharp (F#). The Shinya staff continues the drum pattern from the previous system. The Kaoru staff has a melodic line with a long note in measure 172. The Die staff consists of block chords, with some notes held over from the previous measure. The Toshiya staff has a bass line with a long note in measure 172. The Kyo staff provides a piano accompaniment with chords and rests.

172

Kaoru



Die

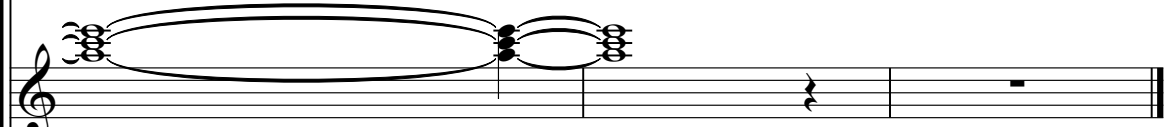

Toshiya



Kyo



Detailed description: This image shows a page of musical notation for a piece numbered 172. The page is numbered 50 in the top left corner. It features four staves, each with a name to its left: Kaoru, Die, Toshiya, and Kyo. The Kaoru staff is in treble clef and contains a melodic line with a long slur over the first two measures. The Die staff is also in treble clef and features a complex chordal structure with multiple notes beamed together and a long slur. The Toshiya staff is in bass clef and contains a melodic line with a long slur. The Kyo staff is in treble clef and contains a more rhythmic and melodic line. The notation includes various note values, slurs, and rests.

♩ = 151,000381

4

7

10

13

17

20

23

25

27

6/4

30

6/4 4/4

34

38

42

47

**2**

52

56

60

64

67

71

Musical notation for measure 71, featuring a guitar staff with a treble clef and a double bar line. The staff contains a sequence of notes and rests, with a treble clef and a double bar line. The notes are primarily eighth and sixteenth notes, with some rests. A treble clef and a double bar line are present.

75

Musical notation for measure 75, featuring a guitar staff with a treble clef and a double bar line. The staff contains a sequence of notes and rests, with a treble clef and a double bar line. The notes are primarily eighth and sixteenth notes, with some rests. A treble clef and a double bar line are present.

79

Musical notation for measure 79, featuring a guitar staff with a treble clef and a double bar line. The staff contains a sequence of notes and rests, with a treble clef and a double bar line. The notes are primarily eighth and sixteenth notes, with some rests. A treble clef and a double bar line are present.

82

Musical notation for measure 82, featuring a guitar staff with a treble clef and a double bar line. The staff contains a sequence of notes and rests, with a treble clef and a double bar line. The notes are primarily eighth and sixteenth notes, with some rests. A treble clef and a double bar line are present.

85

Musical notation for measure 85, featuring a guitar staff with a treble clef and a double bar line. The staff contains a sequence of notes and rests, with a treble clef and a double bar line. The notes are primarily eighth and sixteenth notes, with some rests. A treble clef and a double bar line are present.

88

Musical notation for measure 88, featuring a guitar staff with a treble clef and a double bar line. The staff contains a sequence of notes and rests, with a treble clef and a double bar line. The notes are primarily eighth and sixteenth notes, with some rests. A treble clef and a double bar line are present.

90

Musical notation for measure 90, featuring a guitar staff with a treble clef and a double bar line. The staff contains a sequence of notes and rests, with a treble clef and a double bar line. The notes are primarily eighth and sixteenth notes, with some rests. A treble clef and a double bar line are present.

92

Musical notation for measure 92, featuring a guitar staff with a treble clef and a double bar line. The staff contains a sequence of notes and rests, with a treble clef and a double bar line. The notes are primarily eighth and sixteenth notes, with some rests. A treble clef and a double bar line are present.

95

Musical notation for measure 95, featuring a guitar staff with a treble clef and a double bar line. The staff contains a sequence of notes and rests, with a treble clef and a double bar line. The notes are primarily eighth and sixteenth notes, with some rests. A treble clef and a double bar line are present.

98

Musical notation for measure 98, featuring a guitar staff with a treble clef and a double bar line. The staff contains a sequence of notes and rests, with a treble clef and a double bar line. The notes are primarily eighth and sixteenth notes, with some rests. A treble clef and a double bar line are present.

V.S.

102

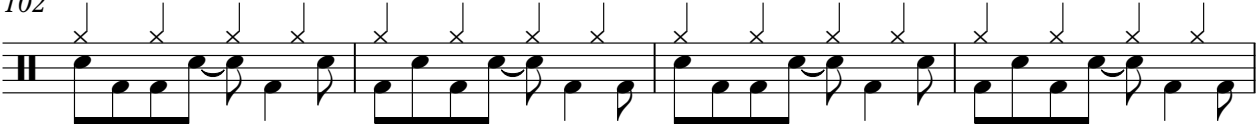

Musical notation for measure 102, featuring a guitar staff with a treble clef and a key signature of one sharp (F#). The notation includes a series of eighth notes and quarter notes, with 'x' marks above the staff indicating fretted notes.

106

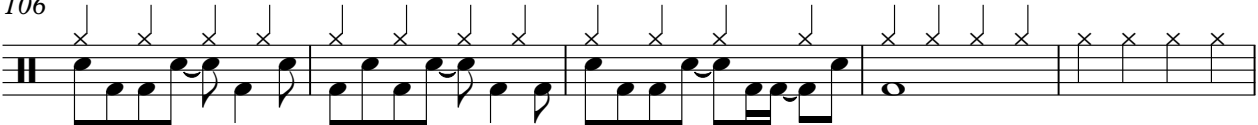

Musical notation for measure 106, featuring a guitar staff with a treble clef and a key signature of one sharp (F#). The notation includes a series of eighth notes and quarter notes, with 'x' marks above the staff indicating fretted notes.

111



Musical notation for measure 111, featuring a guitar staff with a treble clef and a key signature of one sharp (F#). The notation includes a series of eighth notes and quarter notes, with 'x' marks above the staff indicating fretted notes. A double bar line with a '2' above it indicates a measure rest.

117

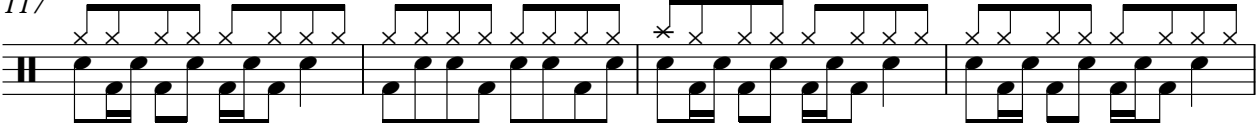

Musical notation for measure 117, featuring a guitar staff with a treble clef and a key signature of one sharp (F#). The notation includes a series of eighth notes and quarter notes, with 'x' marks above the staff indicating fretted notes.

121

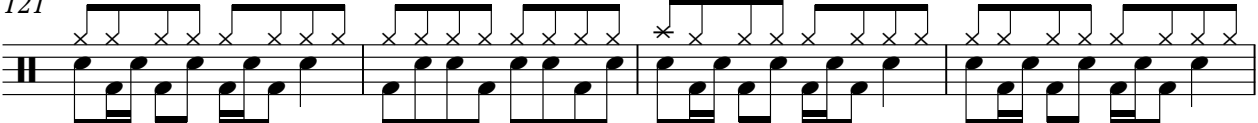

Musical notation for measure 121, featuring a guitar staff with a treble clef and a key signature of one sharp (F#). The notation includes a series of eighth notes and quarter notes, with 'x' marks above the staff indicating fretted notes.

125

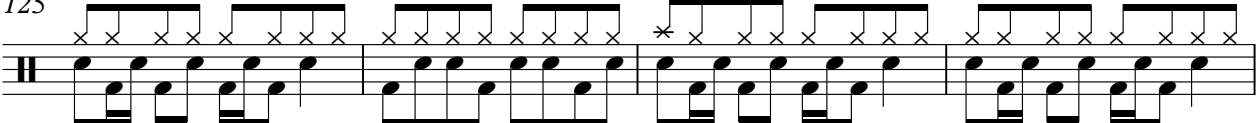

Musical notation for measure 125, featuring a guitar staff with a treble clef and a key signature of one sharp (F#). The notation includes a series of eighth notes and quarter notes, with 'x' marks above the staff indicating fretted notes.

129



Musical notation for measure 129, featuring a guitar staff with a treble clef and a key signature of one sharp (F#). The notation includes a series of eighth notes and quarter notes, with 'x' marks above the staff indicating fretted notes.

133



Musical notation for measure 133, featuring a guitar staff with a treble clef and a key signature of one sharp (F#). The notation includes a series of eighth notes and quarter notes, with 'x' marks above the staff indicating fretted notes.

137

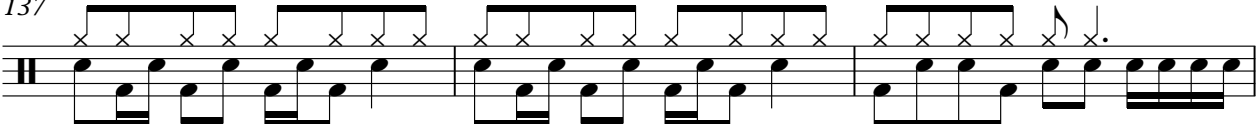

Musical notation for measure 137, featuring a guitar staff with a treble clef and a key signature of one sharp (F#). The notation includes a series of eighth notes and quarter notes, with 'x' marks above the staff indicating fretted notes.

140

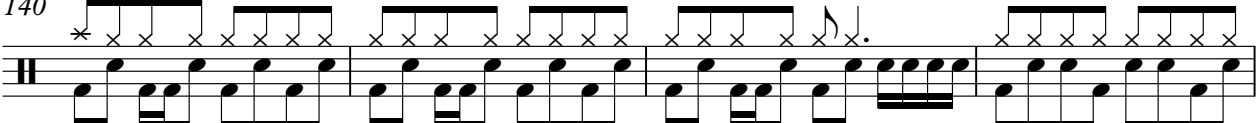

Musical notation for measure 140, featuring a guitar staff with a treble clef and a key signature of one sharp (F#). The notation includes a series of eighth notes and quarter notes, with 'x' marks above the staff indicating fretted notes.

144

Musical notation for measure 144, featuring a guitar staff with a treble clef and a double bar line. The notation includes a sequence of eighth notes with 'x' marks above them, indicating fretted notes. The measure concludes with a quarter note followed by a quarter rest.

148

Musical notation for measure 148, featuring a guitar staff with a treble clef and a double bar line. The notation includes a sequence of eighth notes with 'x' marks above them, indicating fretted notes. The measure concludes with a quarter note followed by a quarter rest.

152

Musical notation for measure 152, featuring a guitar staff with a treble clef and a double bar line. The notation includes a sequence of eighth notes with 'x' marks above them, indicating fretted notes. The measure concludes with a quarter note followed by a quarter rest.

155

Musical notation for measure 155, featuring a guitar staff with a treble clef and a double bar line. The notation includes a sequence of eighth notes with 'x' marks above them, indicating fretted notes. The measure concludes with a quarter note followed by a quarter rest. A 5/4 time signature change is indicated at the start of the next measure.

158

Musical notation for measure 158, featuring a guitar staff with a treble clef and a double bar line. The notation includes a sequence of eighth notes with 'x' marks above them, indicating fretted notes. The measure concludes with a quarter note followed by a quarter rest.

161

Musical notation for measure 161, featuring a guitar staff with a treble clef and a double bar line. The notation includes a sequence of eighth notes with 'x' marks above them, indicating fretted notes. The measure concludes with a quarter note followed by a quarter rest.

164

Musical notation for measure 164, featuring a guitar staff with a treble clef and a double bar line. The notation includes a sequence of eighth notes with 'x' marks above them, indicating fretted notes. The measure concludes with a quarter note followed by a quarter rest.

167

Musical notation for measure 167, featuring a guitar staff with a treble clef and a double bar line. The notation includes a sequence of eighth notes with 'x' marks above them, indicating fretted notes. The measure concludes with a quarter note followed by a quarter rest.

170

Musical notation for measure 170, featuring a guitar staff with a treble clef and a double bar line. The notation includes a sequence of eighth notes with 'x' marks above them, indicating fretted notes. The measure concludes with a quarter note followed by a quarter rest. A '3' is written above the final measure, indicating a triplet.

# Dir En Grey - Aoi Tsuki

Kaoru

♩ = 151,000381

4

7

10

12

15

17

19

21

23

25

V.S.



27



29



31



33



36



39



41



47



50



53



56

59

62

65

68

71

74

77

80

82

V.S.





144

147

150

153

156

158

160

162

164

166

168



170



172

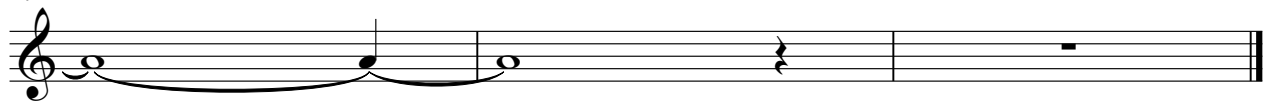

# Dir En Grey - Aoi Tsuki

Die

♩ = 151,000381

4

7

9

11

13

16

18

20

22

24

V.S.

26

28

30

33

37

40

44

51

55

59



63

67

73

78

81

83

85

87

89

91

93

95

97

101

104

108

116

120

124

128



6

Die

166



Musical staff for measure 166, featuring a treble clef, a key signature of two sharps (F# and C#), and a series of chords. The staff contains 16 measures of music, with a double bar line after the 8th measure. The chords are primarily triads and dyads, with some more complex voicings.

168



Musical staff for measure 168, featuring a treble clef, a key signature of two sharps (F# and C#), and a series of chords. The staff contains 16 measures of music, with a double bar line after the 8th measure. The chords are primarily triads and dyads, with some more complex voicings.

170



Musical staff for measure 170, featuring a treble clef, a key signature of two sharps (F# and C#), and a series of chords. The staff contains 16 measures of music, with a double bar line after the 8th measure. The chords are primarily triads and dyads, with some more complex voicings.

171

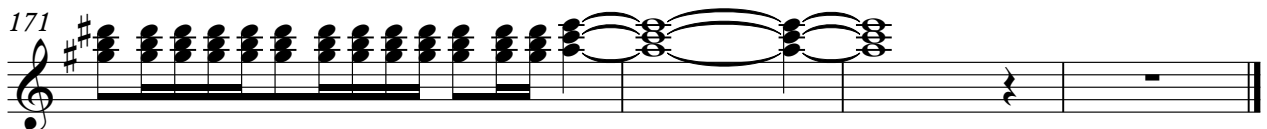

Musical staff for measure 171, featuring a treble clef, a key signature of two sharps (F# and C#), and a series of chords. The staff contains 16 measures of music, with a double bar line after the 8th measure. The chords are primarily triads and dyads, with some more complex voicings.



36



40



44



49



53



57



61



65



69



73



77



81



84



87



90



93



96



99



103



107



V.S.

111

2

116

120

124

128

133

137

141

145

149



153



157



160



163



166



169



171



# Dir En Grey - Aoi Tsuki

Kyo

♩ = 151,000381

4 8 4

19

23

26 6/4

30

36

42 2

49

55

60





165



168



171

