

Anonymous - Title 11

♩ = 145,000031

Musical score for measures 1-4. The score includes parts for Flute, Clarinet in Bb, Percussion, Jazz Guitar, Electric Bass, and Solo. The time signature is 4/4. The Flute part has rests in measures 1-3 and a melodic phrase in measure 4. The Clarinet in Bb part has rests in measures 1-3 and a rhythmic pattern in measure 4. The Percussion part features a complex rhythmic pattern with accents and slurs. The Jazz Guitar part is shown as a guitar tab with strings T, A, G, B, D and fret numbers. The Electric Bass part has a melodic line with slurs. The Solo part has a simple harmonic accompaniment.

Musical score for measures 5-7. The score includes parts for Fl. (Flute), Cl. (Clarinet in Bb), Perc. (Percussion), J. Gtr. (Jazz Guitar), and E. Bass (Electric Bass). The time signature is 4/4. The Fl. part has a melodic line with a triplet in measure 7. The Cl. part has a rhythmic pattern. The Perc. part features a complex rhythmic pattern with accents and slurs. The J. Gtr. part is shown as a guitar tab with strings T, A, G, B, D and fret numbers. The E. Bass part has a melodic line with slurs.

Copyright par DM Midi conf-x-ion

8

Fl.

Cl.

Perc.

J. Gtr.

E. Bass

Tab for J. Gtr. (Measures 8-10):

Measure	T	A	B
8	0 3 0 3 0	0 0 0	5 0 0
9	1 2 2 0 0	0 2 2	5 0 0
10	0 0 2 2 0 0	1 1 4 4 2 2	5 5 0 0

11

Cl.

Perc.

J. Gtr.

E. Bass

Tab for J. Gtr. (Measures 11-13):

Measure	T	A	B
11	0 3 0 3 0	0 0 0	3 3 3 3 3
12	0 2 0 2 0 0	0 3 0 3 0 0	3 3 3 3 3
13	0 0 3 5 3	3 5 3 3 3	3 3 3 3

14

Cl.

Perc.

J. Gtr.

E. Bass

16

Fl.

Cl.

Perc.

J. Gtr.

E. Bass

19

Cl.

Perc.

J. Gtr.

E. Bass

21

Cl.

Perc.

J. Gtr.

E. Bass

23

Cl.

Perc.

J. Gtr.

E. Bass

25

Fl.

Cl.

Perc.

J. Gtr.

E. Bass

T 0 0 2 2 0 2 2 2 0 2 2 2 0 2

A 2 2 4 4 2 4 4 4 2 4 4 4 0 0

B 0 0 0 0 0 0 5 3 2

27

Fl.

Cl.

Perc.

J. Gtr.

E. Bass

T 2 0 0 0 3 3 3 0 3 0 0 0 0 0

A 5 3 5 3 3 3 5 8 1 5 3 5 3 3

B 3 3 3 3 1 1 1 8 1 3 3 3 3 3

30

Cl.

Perc.

J. Gtr.

E. Bass

Solo

33

Cl.

Perc.

J. Gtr.

E. Bass

35

Fl.

Cl.

Perc.

J. Gtr.

E. Bass

Flute and Clarinet staves show melodic lines. Percussion has a complex rhythmic pattern with 'x' marks. J. Gtr. has a tab with triplets and other fret numbers. E. Bass has a bass line with slurs and accents.

38

Fl.

Cl.

Perc.

J. Gtr.

E. Bass

Flute and Clarinet staves show melodic lines. Percussion has a complex rhythmic pattern with 'x' marks. J. Gtr. has a tab with triplets and other fret numbers. E. Bass has a bass line with slurs and accents.

41

Fl.

Perc.

J. Gtr.

E. Bass

43

Fl.

Cl.

Perc.

J. Gtr.

E. Bass

45

Cl.

Perc.

J. Gtr.

E. Bass

47

Fl.

Cl.

Perc.

J. Gtr.

E. Bass

T 0 2 2 2 0 0 3 0 0 0 0 2 2 2 0 0

A 0 0 0 0 0 0 2 0 0 0 0 4 0 4 0 0

B 0 0 0 0 0 0 5 5 5 0 0 0 0 0 0

50

Fl.

Cl.

Perc.

J. Gtr.

E. Bass

T 0 2 0 0 0 3 0 0 0 0 0 2 2 2 0 0

A 0 0 0 3 2 0 0 0 0 0 0 3 3 3 0 0

B 0 5 3 2 0 0 0 0 3 3 3 3

53

Cl.

Perc.

J. Gtr.

E. Bass

56

Fl.

Cl.

Perc.

J. Gtr.

E. Bass

58

Fl. Cl. Perc. J. Gtr. E. Bass

J. Gtr. Tablature:
T: 2 0 0 0 0 0 1 3 1 3 3
A: 0 0 3 3 5 3 5 5 3
B: 0 5 3 2 3 3 3 3 1 1 1 1 1

61

Cl. Perc. J. Gtr. E. Bass Solo

J. Gtr. Tablature:
T: 0 0 0 0 0 0 0 0 0 0
A: 3 5 5 5 3 3 3 3 5 5 5 3 3
B: 3 3 3 3 3 1 1 3 3 3 3 3

64

Cl.

Perc.

J. Gtr.

E. Bass

66

Cl.

Perc.

J. Gtr.

E. Bass

Solo

68

Cl.

Perc.

J. Gtr.

E. Bass

Solo

71

Fl.

Perc.

J. Gtr.

E. Bass

Solo

73

Fl. Treble clef, melodic line with eighth notes and a quarter note.

Perc. Percussion line with 'x' marks and eighth notes.

J. Gtr. Treble clef, guitar tabs for T, A, B strings.

E. Bass Bass clef, melodic line with eighth notes.

Solo Treble clef, chordal accompaniment with triplets.

75

Fl. Treble clef, melodic line with sixteenth-note triplets.

Perc. Percussion line with 'x' marks and eighth notes.

J. Gtr. Treble clef, guitar tabs for T, A, B strings.

E. Bass Bass clef, melodic line with eighth notes.

Solo Treble clef, chordal accompaniment with eighth notes.

77 15

Fl.

Cl.

Perc.

J. Gtr.

E. Bass

Solo

79

Fl.

Cl.

Perc.

J. Gtr.

E. Bass

Solo

81

Fl. Cl. Perc. J. Gtr. E. Bass Solo

Detailed description: This system contains measures 81 and 82. The Flute (Fl.) part has a melodic line with a triplet in measure 82. The Clarinet (Cl.) part is silent. The Percussion (Perc.) part features a rhythmic pattern of eighth notes with 'x' marks above them. The J. Gtr. part shows guitar tablature for Treble (T), Acoustic (A), and Bass (B) strings. The Electric Bass (E. Bass) part has a bass line. The Solo part features a complex melodic line with various articulations.

83

Fl. Cl. Perc. J. Gtr. E. Bass Solo

Detailed description: This system contains measures 83, 84, and 85. The Flute (Fl.) part has a melodic line with a long note in measure 83. The Clarinet (Cl.) part is silent. The Percussion (Perc.) part continues with a rhythmic pattern. The J. Gtr. part shows guitar tablature. The Electric Bass (E. Bass) part has a bass line. The Solo part features a complex melodic line with various articulations.

86

Fl. Cl. Perc. J. Gtr. E. Bass Solo

This system contains measures 86 and 87. The Flute (Fl.) part features a melodic line with eighth notes and a long note in measure 87. The Clarinet (Cl.) part is silent. The Percussion (Perc.) part has a rhythmic pattern of eighth notes and a series of 'x' marks in measure 87. The J. Gtr. part shows a guitar tab with fret numbers (0, 2, 5) and a triplet in measure 87. The E. Bass part has a bass line with eighth notes and a long note in measure 87. The Solo part features a melodic line with a triplet in measure 86 and a long note in measure 87.

88

Fl. Cl. Perc. J. Gtr. E. Bass Solo

This system contains measures 88 and 89. The Flute (Fl.) part has a melodic line with eighth notes and a long note in measure 89. The Clarinet (Cl.) part is silent. The Percussion (Perc.) part has a rhythmic pattern of eighth notes and 'x' marks. The J. Gtr. part shows a guitar tab with fret numbers (0, 2, 3, 5) and triplets in measure 89. The E. Bass part has a bass line with eighth notes and a long note in measure 89. The Solo part features a melodic line with a triplet in measure 88 and a long note in measure 89.

90

Fl.

Cl.

Perc.

J. Gtr.

E. Bass

Solo

Detailed description: This system contains measures 90, 91, and 92. The Flute part (Fl.) has a melodic line in measure 90, followed by rests in 91 and 92. The Clarinet part (Cl.) has rests in 90 and 91, then a melodic line in 92. Percussion (Perc.) features a rhythmic pattern of eighth notes in 90, rests in 91, and a pattern of eighth notes with 'x' marks in 92. The J. Gtr. part shows guitar tablature for strings T, A, and B. The E. Bass part has a melodic line in 90, rests in 91, and a melodic line in 92. The Solo part has a melodic line in 90, rests in 91 and 92.

Measure	T	A	B
90	0 1 0	0 0	0
91	0 0	3 3 2 0	5 3 2 0
92	2 2	0 0 0 0	3 3 3 3 3

93

Cl.

Perc.

J. Gtr.

E. Bass

Detailed description: This system contains measures 93, 94, and 95. The Clarinet part (Cl.) has a melodic line in 93, rests in 94, and a melodic line in 95. Percussion (Perc.) features a rhythmic pattern of eighth notes with 'x' marks in 93, eighth notes in 94, and eighth notes with 'x' marks in 95. The J. Gtr. part shows guitar tablature for strings T, A, and B. The E. Bass part has a melodic line in 93, rests in 94, and a melodic line in 95.

Measure	T	A	B
93	0 0 0	3 3 3	3 3 3
94	0 0 0	3 3 3	3 3 3
95	2 2 2 0 0 0	0 0 0 0 0 2 2	2 7 2 2 2 2

95

Cl.

Perc.

J. Gtr.

E. Bass

Solo

Detailed description: This system covers measures 95, 96, and 97. The Clarinet part features a melodic line with eighth and sixteenth notes, including a triplet in measure 97. The Percussion part has a consistent rhythmic pattern of eighth notes with 'x' marks above them. The J. Gtr. part shows fret numbers for the Top (T), Adornment (A), and Bass (B) strings. The E. Bass part provides a steady bass line. The Solo part is mostly silent, with some notes appearing in measure 97.

98

Cl.

Perc.

J. Gtr.

E. Bass

Solo

Detailed description: This system covers measures 98, 99, and 100. The Clarinet part continues with a melodic line, featuring a triplet in measure 98 and a 7-measure rest in measure 99. The Percussion part maintains its rhythmic pattern. The J. Gtr. part shows fret numbers for the T, A, and B strings. The E. Bass part continues with a steady bass line. The Solo part has some notes in measure 98 and 100.

100

Cl.

Perc.

J. Gtr.

E. Bass

Solo

103

Cl.

Perc.

J. Gtr.

E. Bass

Solo

105

Fl.

Cl.

Perc.

J. Gtr.
T
A
B

E. Bass

Solo

Detailed description: This system covers measures 105, 106, and 107. The Flute (Fl.) part is mostly silent, with some notes in measure 107. The Clarinet (Cl.) plays a rhythmic pattern of eighth notes. The Percussion (Perc.) part features a complex rhythmic pattern with many rests. The J. Gtr. (Jazz Guitar) part includes a tab for the bass strings (T, A, B) with fret numbers like 0, 2, 3, 5 and triplets. The Electric Bass (E. Bass) and Solo parts provide harmonic support with various note values and rests.

108

Fl.

Cl.

Perc.

J. Gtr.
T
A
B

E. Bass

Solo

Detailed description: This system covers measures 108, 109, and 110. The Flute (Fl.) and Clarinet (Cl.) parts have more active lines with notes and rests. The Percussion (Perc.) continues with its rhythmic pattern. The J. Gtr. (Jazz Guitar) part includes a tab for the bass strings (T, A, B) with fret numbers like 0, 2, 3, 5 and triplets. The Electric Bass (E. Bass) and Solo parts continue their respective parts, providing a solid harmonic foundation.

111

Fl.

Cl.

Perc.

J. Gtr.

E. Bass

Solo

T 0 3 5 0 5 0 0 0 2 3

A 0 0 0 0 0 0 0 0 2 3

B 0 0 0 0 0 5 0 0 2 3

113

Fl.

Cl.

Perc.

J. Gtr.

E. Bass

Solo

T 0 3 5 0 3 0 0 0 2 3

A 0 0 0 0 0 0 0 0 2 3

B 0 0 0 0 0 5 0 0 2 3

115

Fl. Perc. J. Gtr. E. Bass Solo

This musical score covers measures 115 and 116. The Flute part features a melodic line with eighth notes and rests. The Percussion part has a steady eighth-note rhythm with occasional accents. The J. Gtr. part includes a guitar tab with fret numbers (0, 1, 2, 4, 5) for the Treble and Bass staves. The E. Bass part plays a simple eighth-note bass line. The Solo part consists of sustained chords in the right hand and a bass line in the left hand.

117

Fl. Perc. J. Gtr. E. Bass Solo

This musical score covers measure 117. The Flute part has a melodic line with eighth notes and a triplet of eighth notes. The Percussion part has a single eighth note followed by a rest. The J. Gtr. part includes a guitar tab with fret numbers (3, 5, 1) for the Treble and Bass staves. The E. Bass part has a single eighth note followed by a long sustain line. The Solo part has a long sustain line with a double bar line at the end.

118

Fl.



J. Gtr.

T	3	3
A	3	3
B	1	1

E. Bass

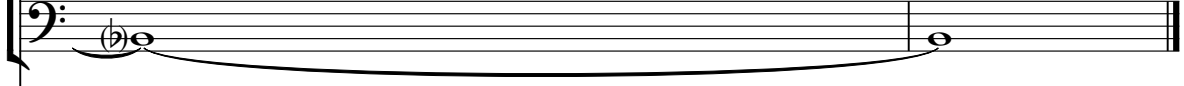

Solo

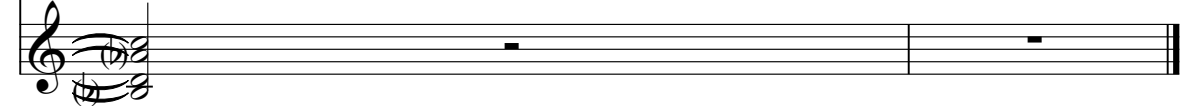

Detailed description: This page contains musical notation for four instruments: Flute (Fl.), Jazz Guitar (J. Gtr.), Electric Bass (E. Bass), and Solo. The Flute part (measures 118-119) features a melodic line with eighth and sixteenth notes, including slurs and accents. The Jazz Guitar part (measures 118-119) is a guitar tab with fret numbers 3, 3, 1 on the top three strings. The Electric Bass part (measures 118-119) shows a sustained bass line with a slur connecting the two measures. The Solo part (measures 118-119) consists of whole rests on a grand staff.

Flute

Anonymous - Title 11

♩ = 145,000031

3

8

6

18

6

27

7

38

3

42

3

5

51

5

58

11

Copyright par DM Midi conf-x-ion

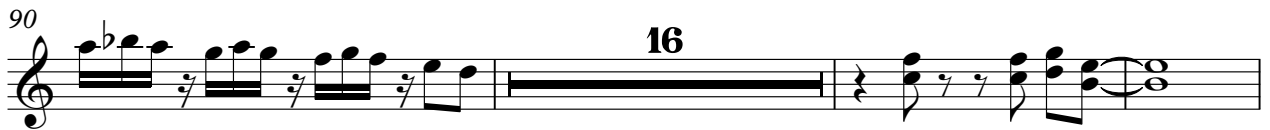

2

Clarinet in B \flat

51

54

59

64

70

87

94

99

103

108

Clarinet in B♭

112

5

Anonymous - Title 11

Percussion

♩ = 145,000031

6

10

14

18

22

26

30

34

38

Copyright par DM Midi conf-x-ion

V.S.

42

Musical notation for measures 42-45. The top staff shows a series of eighth notes with 'x' marks above them, indicating a specific rhythmic pattern. The bottom staff shows a corresponding bass line with eighth notes.

46

Musical notation for measures 46-49. The top staff shows a series of eighth notes with 'x' marks above them. The bottom staff shows a corresponding bass line with eighth notes.

50

Musical notation for measures 50-53. The top staff shows a series of eighth notes with 'x' marks above them. The bottom staff shows a corresponding bass line with eighth notes.

54

Musical notation for measures 54-57. The top staff shows a series of eighth notes with 'x' marks above them. The bottom staff shows a corresponding bass line with eighth notes.

58

Musical notation for measures 58-61. The top staff shows a series of eighth notes with 'x' marks above them. The bottom staff shows a corresponding bass line with eighth notes.

62

Musical notation for measures 62-65. The top staff shows a series of eighth notes with 'x' marks above them. The bottom staff shows a corresponding bass line with eighth notes.

66

Musical notation for measures 66-69. The top staff shows a series of eighth notes with 'x' marks above them. The bottom staff shows a corresponding bass line with eighth notes.

70

Musical notation for measures 70-73. The top staff shows a series of eighth notes with 'x' marks above them. The bottom staff shows a corresponding bass line with eighth notes.

74

Musical notation for measures 74-77. The top staff shows a series of eighth notes with 'x' marks above them. The bottom staff shows a corresponding bass line with eighth notes.

78

Musical notation for measures 78-81. The top staff shows a series of eighth notes with 'x' marks above them. The bottom staff shows a corresponding bass line with eighth notes.

Percussion

82

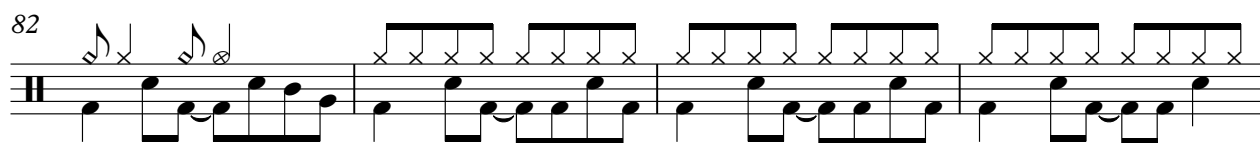

86

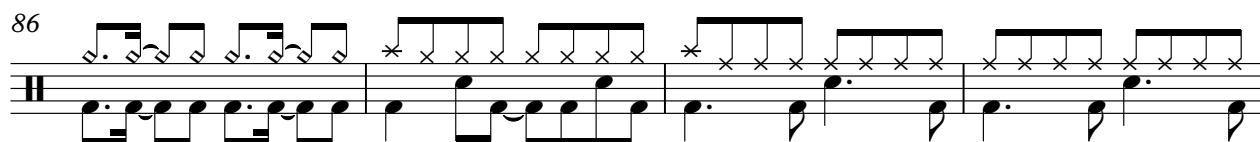

90

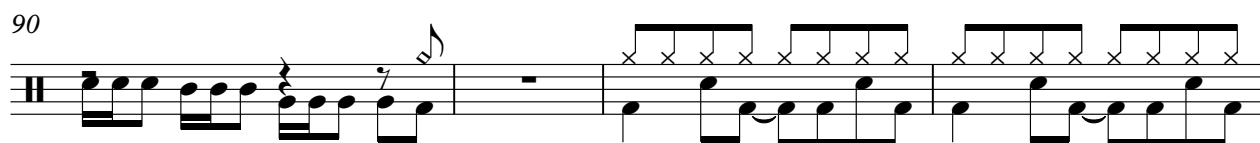

94



98



102

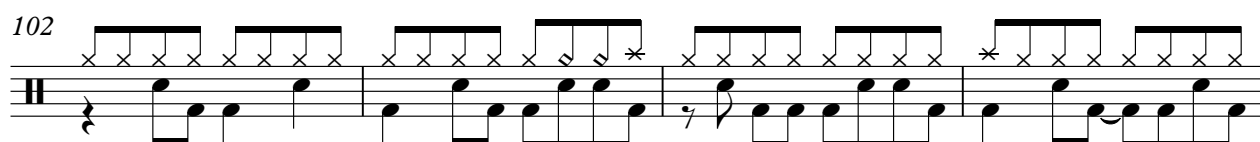

106

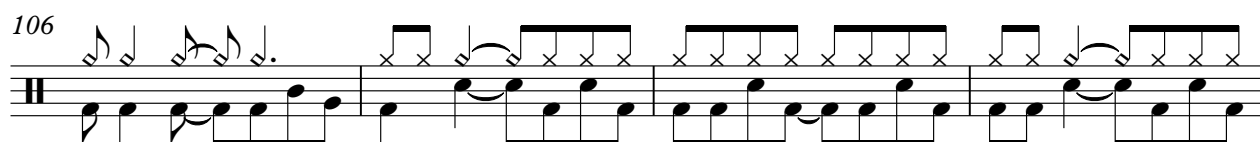

110

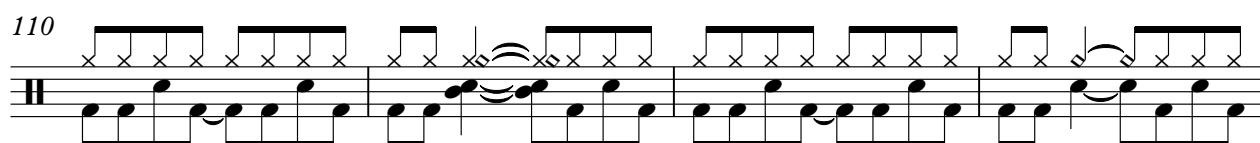

114



Anonymous - Title 11

Jazz Guitar

♩ = 145,000031

2

Measures 1-4 of the piece. The notation is for a 2-measure phrase. The strings are labeled T (Treble), A (Acoustic), B (Bass), and D (Drum). The notes are: T: 0 0 2 3; A: 0 0 0 0; B: 1 1; D: 5 0 2 3.

7

Measures 5-8. The notation is for a 4-measure phrase. The notes are: T: 0 0 2 3; A: 0 0 0 0; B: 5 0 2 3; D: 5 0 0 0.

11

Measures 9-12. The notation is for a 4-measure phrase. The notes are: T: 0 5 0 5 0; A: 0 0 0 0; B: 3 3 3 3; D: 3 3 3 3.

15

Measures 13-16. The notation is for a 4-measure phrase. The notes are: T: 0 4 0 0 0; A: 0 0 0 0; B: 0 0 0 0; D: 5 5 5 0.

18

Measures 17-20. The notation is for a 4-measure phrase. The notes are: T: 0 0 0 0; A: 0 3 2; B: 0 5 3 2; D: 0 5 0 0.

21

Measures 21-23. The notation is for a 3-measure phrase. The notes are: T: 0 0 0; A: 3 3 3; B: 3 3 3; D: 2 2 2.

24

Measures 24-26. The notation is for a 3-measure phrase. The notes are: T: 0 5 0 2; A: 0 0 0; B: 5 5 5; D: 0 0 0.

27

Measures 27-30. The notation is for a 4-measure phrase. The notes are: T: 0 0 0; A: 3 3 3; B: 3 3 3; D: 1 1 1.

31

Measures 31-33. The notation is for a 3-measure phrase. The notes are: T: 1 0 0; A: 3 5 3; B: 3 3 3; D: 1 1 1.

34

Measures 34-37. The notation is for a 4-measure phrase. The notes are: T: 5 0 7 0; A: 6 6 6 6; B: 0 0 0 0; D: 0 2 0 0.

38

T	0	0	2	3	0	5	0	5	0	0	3	3	3	0	0	0	0	
A	0	0	2	3	0	0	0	0	0	0	0	0	0	0	3	5	5	3
B	5	0	2	3	3	3	3	3	3	3	3	3	3	3	3	3	3	3

42

42

T	0	0	0	5	0	0	5	0	0	0	0	2	3	3	3	0	0	0
A	0	3	0	0	0	0	0	0	0	0	0	0	0	0	0	3	5	3
B	0	5	3	2	3	3	3	3	3	3	3	3	3	3	3	3	3	3

46

46

T	2	2	2	2	0	4	0	2	2	0	0	0	3	0	0	0	0
A	2	2	2	2	2	2	2	0	0	0	0	0	0	2	0	2	2
B	2	2	2	2	2	2	2	0	0	0	0	0	0	5	5	5	5

49

49

T	0	0	2	2	2	0	0	0	2	0	0	0	3	0	0	0	0
A	0	0	0	0	0	0	0	0	0	0	3	2	0	0	0	0	0
B	0	0	0	0	0	0	5	3	2	0	0	0	0	3	3	3	3

53

53

T	2	2	2	2	0	2	2	2	0	0	3	0	0	3	0	0	0
A	0	0	0	0	2	2	2	2	0	0	0	2	0	2	0	0	0
B	3	2	2	2	2	2	2	2	0	0	0	0	0	0	5	5	5

57

57

T	0	0	2	2	2	0	0	0	2	0	0	0	0	0	0	0	0
A	0	0	0	0	0	0	0	0	0	0	3	0	3	5	5	5	3
B	0	0	0	0	0	0	5	3	2	0	0	0	0	3	3	3	3

60

60

T	1	5	1	5	1	1	0	0	0	0	1	0	0	0	0	0	0
A	1	1	1	1	1	1	3	3	3	3	3	3	3	3	3	3	3
B	1	1	1	1	1	1	3	3	3	3	3	1	1	3	3	3	3

64

64

T	0	0	0	0	0	0	0	2	0	2	0	0	5	0	5	5	5
A	3	3	3	3	3	3	3	0	4	0	0	4	0	0	7	0	7
B	1	1	1	1	1	1	0	0	0	0	0	0	0	0	6	6	6

67

67

T	0	5	0	0	5	0	0	0	2	3	3	0	5	0	0	0	0
A	0	0	0	0	0	0	0	0	0	2	3	0	0	0	0	0	0
B	0	0	0	0	0	0	5	0	2	3	3	0	0	0	0	0	0

71

71

T	3	0	5	0	5	0	0	0	0	2	3	0	5	0	0	5	0
A	0	0	0	0	0	0	0	0	0	2	3	0	0	0	0	0	0
B	0	0	0	0	0	0	5	0	2	3	3	0	0	0	0	0	0

75

T	0 5 0 0 5 0 0	0 0 2 3	0 5 0 0 5 0 0	0 2 2 2
A	0 0 0 0 0 0	0	0 0 0 0 0	0 2 2
B	5	0 2 3	5	0 0

79

T	0 5 0 0 5 0 0	2 2 2	0 0 5 0 5 0 0
A	0 0 0 0 0	3 3 3	0 0 0 0 0
B	3 3	3 3	3 3

82

T	0 0 0 0	0 5 3 0 5 5 0	0 0 2 3	0 5 0 5 0 0
A	0	0 0 2 0	0	0 0 0 0 0
B	5	0 0 0	5	0 2 3

86

T	0 0 0 2 0 0 0 2	0 5 0 5 0 0 0	0 0 5 0 5 0 0
A	0 0 0 2 0 0 2	0 0 0 0 0 0	0 0 0 0 0
B	5 0 0 2 5 0 0 2	3 3	3 3 3

89

T	0 0 0	0 1 0 0 0 0	2 2 2
A	0 5 5 5	0 0 0 0 0 0	0 0 0 0 0
B	3 3 3 3 3 3	0 5 3 2 0	3 3 3 3 3

93

T	0 0 0	2 2 2	2 0 0 0
A	3 5 5 5	3 0 0 0 0 0	3 5 5 5
B	3 3 3 3 3	2 7 2 2 2 2	3 3 3 3 3

96

T	2 2 2	5 0 5 5 0	0 3 3 3	2 0 5 0 5 0
A	3 2 0 0 0 0	0 0 2 0	0 0 0 0 0 0	0 0 0 0
B	2 2 2 2	0 0 0 0	3 3 3 3 3	3 3

100

T	0 3 3 3	0 5 5 0 5 5	2 2 2 2	0 3 3 3 3
A	0 0 0 0	0 2 0 0 2 0	0 0 0 0	0 2 0 0 2 0
B	3 3 3 3	0 0 0 3	3 3 3 3 3	0 0 0 3

104

T	0 3 3 3	0 5 5 0 0 0	0 0 2 3
A	0 0 0 0	0 0 0 0 0 0	0 0 2 3
B	3 3 3 3 3	0 0 0 0 0 0	5 0 2 3

107

T	0 5 0 0 5 0 0	0 0 2 3	0 5 0 0 5 0	0 0 2 3
A	0 0 0 0 0	0	0 0 0 0 0	0 0 2 3
B	5	0 2 3	5	0 2 3

V.S.

T	0	5	0	5	0	0	0	2	3	0	5	0	5	0	0	0	2	3
A	0	0	0	0	0	0	0	0	0	0	0	0	0	0	0	0	0	0
B						5	0	2	3						5	0	2	3

T	0	0	2	2	0	0	2	2	3	3	3	3	3
A	1	1	4	4	1	1	4	4	5	5	5	5	5
B	0	0	2	2	0	0	2	2	3	3	3	3	3
	5	5	0	0	5	5	0	0	1	1	1	1	1

Anonymous - Title 11

Electric Bass

♩ = 145,000031



Copyright par DM Midi conf-x-ion

V.S.

44



48



53



58



63



68



72



76



81



85



89



93



97



102



107



111



115



Anonymous - Title 11

Solo

♩ = 145,000031

2 26

31 4

68

71

74

78

81

84

87

89 6

Copyright par DM Midi conf-ion

97

101

104

108

112

115