

Espagnol+Portugais - caco@mundivia.es Quiero tener tu

$\text{♩} = 145,000031$

Jazz Guitar

3

Perc.

J. Gtr.

5

Perc.

J. Gtr.

7

Perc.

J. Gtr.

9

Perc.

J. Gtr.

E. Bass

2

10

Perc. J. Gtr. E. Bass

This system contains measures 10 and 11. The Percussion part features a consistent rhythmic pattern of eighth notes with 'x' marks above them. The J. Gtr. part has a melodic line with a key signature of one sharp (F#) and a mix of eighth and quarter notes. The E. Bass part provides a steady bass line with quarter and eighth notes.

11

Perc. J. Gtr. E. Bass

This system contains measures 12 and 13. The Percussion part continues with the same eighth-note pattern. The J. Gtr. part shows a more complex melodic structure with some beamed eighth notes and a key signature change to two sharps (F# and C#). The E. Bass part maintains a rhythmic accompaniment with quarter notes.

12

Perc. J. Gtr. E. Bass

This system contains measures 14 and 15. The Percussion part remains consistent. The J. Gtr. part continues its melodic development with a key signature of two sharps. The E. Bass part provides a solid foundation with quarter and eighth notes.

13

Perc. J. Gtr. E. Bass

This system contains measures 13 and 14. The Percussion part features a consistent rhythmic pattern of eighth notes with 'x' marks above them. The J. Gtr. part has a melodic line with a key signature of one sharp (F#) and a mix of eighth and quarter notes. The E. Bass part provides a steady accompaniment with eighth notes and quarter notes.

15

Perc. J. Gtr. E. Bass

This system contains measures 15 and 16. The Percussion part continues with the same eighth-note pattern. The J. Gtr. part features a more complex melodic line with some sixteenth-note runs and slurs. The E. Bass part maintains the accompaniment with eighth and quarter notes.

16

Perc. J. Gtr. E. Bass

This system contains measures 17 and 18. The Percussion part continues with the eighth-note pattern. The J. Gtr. part has a melodic line with a key signature of one sharp (F#) and includes some slurs. The E. Bass part continues with the accompaniment of eighth and quarter notes.

17

Perc. J. Gtr. E. Bass FX 5

This system contains measures 17 and 18. The Percussion part features a consistent rhythmic pattern of eighth notes with 'x' marks above them. The J. Gtr. part has a melodic line with slurs and ties. The E. Bass part provides a steady bass line with slurs. The FX 5 part has a melodic line with slurs and ties.

19

Perc. J. Gtr. E. Bass FX 5

This system contains measures 19 and 20. The Percussion part continues with the eighth-note pattern. The J. Gtr. part has a melodic line with slurs and ties. The E. Bass part provides a steady bass line with slurs. The FX 5 part has a melodic line with slurs and ties.

20

Perc. J. Gtr. E. Bass FX 5

This system contains measures 21 and 22. The Percussion part continues with the eighth-note pattern. The J. Gtr. part has a melodic line with slurs and ties. The E. Bass part provides a steady bass line with slurs. The FX 5 part has a melodic line with slurs and ties.

22

Perc.

J. Gtr.

E. Bass

3

Detailed description: This system contains measures 22 and 23. The Percussion staff features a complex rhythmic pattern with 'x' marks above notes. The J. Gtr. staff has a melodic line with a triplet of eighth notes in measure 23. The E. Bass staff provides a bass line with various rhythmic values. The key signature has one sharp (F#).

23

Perc.

J. Gtr.

E. Bass

Detailed description: This system contains measures 23 and 24. The Percussion staff continues the rhythmic pattern. The J. Gtr. staff has a melodic line with a triplet of eighth notes in measure 24. The E. Bass staff provides a bass line with various rhythmic values. The key signature has one sharp (F#).

24

Perc.

J. Gtr.

E. Bass

FX 5

Detailed description: This system contains measures 24 and 25. The Percussion staff continues the rhythmic pattern. The J. Gtr. staff has a melodic line with a triplet of eighth notes in measure 25. The E. Bass staff provides a bass line with various rhythmic values. The FX 5 staff has a melodic line with a triplet of eighth notes in measure 25. The key signature has one sharp (F#).

26

Perc.

J. Gtr.

E. Bass

FX 5

This system contains measures 26 and 27. The percussion part features a consistent snare drum pattern. The J. Gtr. part has a melodic line with chords, including a prominent chord at the start of measure 26. The E. Bass part provides a steady bass line with some syncopation. The FX 5 part has a rhythmic pattern of eighth notes.

27

Perc.

J. Gtr.

E. Bass

FX 5

This system contains measures 27 and 28. The percussion part continues with the snare drum pattern. The J. Gtr. part continues the melodic line, with some changes in chord voicings. The E. Bass part maintains the bass line. The FX 5 part continues with the eighth-note rhythmic pattern.

28

Perc.

J. Gtr.

E. Bass

FX 5

This system contains measures 28 and 29. The percussion part continues with the snare drum pattern. The J. Gtr. part continues the melodic line. The E. Bass part maintains the bass line. The FX 5 part continues with the eighth-note rhythmic pattern.

29

Perc.

J. Gtr.

E. Bass

FX 5

31

Perc.

E. Gtr.

E. Bass

FX 5

33

Perc.

E. Gtr.

E. Bass

FX 5

35

Perc.

E. Gtr.

E. Bass

FX 5

37

Perc.

E. Gtr.

E. Bass

FX 5

39

Perc.

J. Gtr.

E. Bass

FX 5

40

Perc.

J. Gtr.

E. Bass

Detailed description: This system covers measures 40 and 41. The Percussion part features a consistent rhythmic pattern of eighth notes with 'x' marks above them. The J. Gtr. part has a melodic line with a key signature of one sharp (F#) and a mix of eighth and quarter notes. The E. Bass part provides a steady accompaniment with eighth notes and rests.

41

Perc.

J. Gtr.

E. Bass

Detailed description: This system covers measures 42 and 43. The Percussion part continues with the same eighth-note pattern. The J. Gtr. part shows a change in the melodic line, with some notes beamed together. The E. Bass part maintains its accompaniment pattern.

42

Perc.

J. Gtr.

E. Bass

Detailed description: This system covers measures 44 and 45. The Percussion part remains consistent. The J. Gtr. part continues its melodic development. The E. Bass part provides the same accompaniment.

43

Perc.

J. Gtr.

E. Bass

FX 5

Detailed description: This system covers measures 43 and 44. The Percussion staff features a consistent rhythmic pattern of eighth notes with 'x' marks above them. The J. Gtr. staff has a melodic line with slurs and ties. The E. Bass staff provides a bass line with slurs. The FX 5 staff contains a melodic line with slurs and ties.

45

Perc.

J. Gtr.

E. Bass

FX 5

Detailed description: This system covers measures 45 and 46. The Percussion staff continues with eighth notes and 'x' marks. The J. Gtr. staff has a melodic line with slurs and ties. The E. Bass staff provides a bass line with slurs. The FX 5 staff contains a melodic line with slurs and ties.

46

Perc.

J. Gtr.

E. Bass

FX 5

Detailed description: This system covers measures 47 and 48. The Percussion staff continues with eighth notes and 'x' marks. The J. Gtr. staff has a melodic line with slurs and ties. The E. Bass staff provides a bass line with slurs. The FX 5 staff contains a melodic line with slurs and ties.

48 Perc. J. Gtr. E. Bass

Musical score for measures 48-49. Percussion (Perc.) has a steady eighth-note pattern with 'x' marks above notes. J. Gtr. (J. Gtr.) has a melodic line with a triplet of eighth notes in measure 48. E. Bass (E. Bass) has a bass line with eighth notes and rests.

49 Perc. J. Gtr. E. Bass

Musical score for measures 49-50. Percussion (Perc.) continues with eighth notes. J. Gtr. (J. Gtr.) has a melodic line with a triplet of eighth notes in measure 49. E. Bass (E. Bass) has a bass line with eighth notes and rests.

50 Perc. J. Gtr. E. Bass FX 5

Musical score for measures 50-51. Percussion (Perc.) continues with eighth notes. J. Gtr. (J. Gtr.) has a melodic line with a triplet of eighth notes in measure 50. E. Bass (E. Bass) has a bass line with eighth notes and rests. FX 5 (FX 5) has a melodic line with eighth notes and rests.

52

Perc.

J. Gtr.

E. Bass

FX 5

53

Perc.

J. Gtr.

E. Bass

FX 5

54

Perc.

J. Gtr.

E. Bass

FX 5

55

Perc. J. Gtr. E. Bass FX 5

This system covers measures 55 and 56. The Percussion part features a complex rhythmic pattern with 'x' marks above the notes. The J. Gtr. part has a melodic line with various accidentals. The E. Bass part provides a steady bass line. The FX 5 part has a few notes in the first measure.

57

Perc. E. Gtr. E. Bass FX 5

This system covers measures 57 and 58. The Percussion part has a consistent rhythmic pattern with upward-pointing stems. The E. Gtr. part consists of chords with stems pointing down. The E. Bass part has a steady bass line. The FX 5 part has a melodic line with various accidentals.

59

Perc. E. Gtr. E. Bass FX 5

This system covers measures 59 and 60. The Percussion part has a consistent rhythmic pattern with upward-pointing stems. The E. Gtr. part consists of chords with stems pointing down. The E. Bass part has a steady bass line. The FX 5 part has a melodic line with various accidentals.

61

Perc. E. Gtr. E. Bass FX 5

This system contains measures 61 and 62. The Percussion part features a complex rhythmic pattern with 'x' marks above the staff. The Electric Guitar part has a melodic line with many slurs and ties. The Electric Bass part plays a steady eighth-note line. The FX 5 part has a melodic line with slurs and ties.

63

Perc. E. Gtr. E. Bass FX 5

This system contains measures 63 and 64. The Percussion part continues with its rhythmic pattern. The Electric Guitar part has a melodic line with many slurs and ties. The Electric Bass part plays a steady eighth-note line. The FX 5 part has a melodic line with slurs and ties.

65

Perc. J. Gtr. E. Bass FX 5

This system contains measures 65 and 66. The Percussion part continues with its rhythmic pattern. The Jazz Guitar part has a melodic line with slurs and ties. The Electric Bass part plays a melodic line with slurs and ties. The FX 5 part has a melodic line with slurs and ties.

67

Perc. J. Gtr. E. Bass

This system contains measures 67 and 68. The Percussion part features a consistent rhythmic pattern of eighth notes with 'x' marks above them. The J. Gtr. part has a melodic line with slurs and a triplet in measure 68. The E. Bass part provides a steady bass line with eighth notes and rests.

68

Perc. J. Gtr. E. Bass

This system contains measures 69 and 70. The Percussion part continues with eighth notes and 'x' marks. The J. Gtr. part features a complex melodic line with many beamed notes and a triplet in measure 70. The E. Bass part continues with a bass line of eighth notes and rests.

70

Perc. J. Gtr. E. Bass

This system contains measures 71 and 72. The Percussion part maintains the eighth-note pattern. The J. Gtr. part has a very busy melodic line with many beamed notes and a triplet in measure 72. The E. Bass part continues with a bass line of eighth notes and rests.

72

Perc. J. Gtr. E. Bass

This system contains measures 72 and 73. The Percussion part features a consistent eighth-note pattern. The J. Gtr. part includes a triplet of eighth notes in measure 72 and a series of eighth notes with slurs in measure 73. The E. Bass part provides a bass line with eighth notes and slurs. The key signature has one sharp (F#).

74

Perc. J. Gtr. E. Bass

This system contains measures 74 and 75. The Percussion part continues with the eighth-note pattern. The J. Gtr. part features two triplet markings over eighth notes in measures 74 and 75. The E. Bass part continues with a bass line of eighth notes and slurs. The key signature has one sharp (F#).

76

Perc. J. Gtr. E. Gtr. E. Bass FX 5

This system contains measures 76 and 77. The Percussion part has a more complex pattern with eighth notes and accents. The J. Gtr. part includes a triplet in measure 76 and rests in measure 77. The E. Gtr. part has rests in measure 76 and a chord in measure 77. The E. Bass part continues with a bass line, including a triplet in measure 76. The FX 5 part has rests in measure 76 and a rhythmic pattern in measure 77. The key signature has one sharp (F#).

78

Perc. E. Gtr. E. Bass FX 5

This system covers measures 78 and 79. The Percussion part features a consistent rhythmic pattern of eighth notes with 'x' marks above them. The Electric Guitar part has a sparse accompaniment with chords and single notes. The Electric Bass part plays a steady eighth-note line. The FX 5 part contains a melodic line with various accidentals and slurs.

80

Perc. E. Gtr. E. Bass FX 5

This system covers measures 80 and 81. The Percussion part continues with the eighth-note pattern, including a double bar line in measure 81. The Electric Guitar part introduces a more active melodic line with eighth notes and slurs. The Electric Bass part maintains its eighth-note accompaniment. The FX 5 part continues with its melodic line, featuring a double bar line in measure 81.

82

Perc. E. Gtr. E. Bass FX 5

This system covers measures 82 and 83. The Percussion part continues with the eighth-note pattern. The Electric Guitar part has a more complex melodic line with many slurs and accents. The Electric Bass part continues with the eighth-note accompaniment. The FX 5 part continues with its melodic line, featuring a double bar line in measure 83.

84

Perc. J. Gtr. E. Gtr. E. Bass FX 5

This system contains measures 84 and 85. Measure 84 features a complex percussive pattern with multiple layers of eighth notes and sixteenth notes. The electric guitar (E. Gtr.) plays a rhythmic pattern of eighth notes with a sharp sign. The electric bass (E. Bass) plays a steady eighth-note line. The electric guitar (J. Gtr.) has a whole rest in measure 84. Measure 85 continues the percussive pattern and features melodic lines for the electric guitar (J. Gtr.) and electric bass (E. Bass). A FX 5 track is also present, playing a melodic line with a sharp sign.

86

Perc. J. Gtr. E. Bass

This system contains measures 86 and 87. Measure 86 features a complex percussive pattern with multiple layers of eighth notes and sixteenth notes. The electric guitar (J. Gtr.) plays a melodic line with a sharp sign. The electric bass (E. Bass) plays a steady eighth-note line. Measure 87 continues the percussive pattern and features melodic lines for the electric guitar (J. Gtr.) and electric bass (E. Bass).

87

Perc. J. Gtr. E. Bass

This system contains measures 87 and 88. Measure 87 features a complex percussive pattern with multiple layers of eighth notes and sixteenth notes. The electric guitar (J. Gtr.) plays a melodic line with a sharp sign. The electric bass (E. Bass) plays a steady eighth-note line. Measure 88 continues the percussive pattern and features melodic lines for the electric guitar (J. Gtr.) and electric bass (E. Bass).

88

Perc.

J. Gtr.

E. Bass

This system contains measures 88 and 89. The Percussion staff features a consistent rhythmic pattern of eighth notes with 'x' marks above them. The J. Gtr. staff has a melodic line with a key signature of one sharp (F#) and a mix of eighth and quarter notes. The E. Bass staff provides a bass line with eighth notes and rests. The FX 5 staff is not present in this system.

89

Perc.

J. Gtr.

E. Bass

FX 5

This system contains measures 89 and 90. The Percussion staff continues with the eighth-note pattern. The J. Gtr. staff continues its melodic line. The E. Bass staff continues with eighth notes and rests. The FX 5 staff is introduced in measure 89, featuring a melodic line with eighth notes and rests.

91

Perc.

J. Gtr.

E. Bass

FX 5

This system contains measures 91 and 92. The Percussion staff continues with the eighth-note pattern. The J. Gtr. staff continues its melodic line. The E. Bass staff continues with eighth notes and rests. The FX 5 staff continues with its melodic line.

92

Perc.

J. Gtr.

E. Bass

FX 5

Detailed description: This system covers measures 92 to 94. The Percussion part (Perc.) features a complex rhythmic pattern with many 'x' marks indicating specific hits. The J. Gtr. (Jazz Guitar) part is in a key with one sharp (F#) and features a melodic line with slurs and ties. The E. Bass (Electric Bass) part provides a steady bass line with slurs. The FX 5 (Effects) part has a melodic line with slurs and ties.

94

Perc.

J. Gtr.

E. Bass

Detailed description: This system covers measures 94 to 95. The Percussion part (Perc.) includes a triplet of notes marked with a '3' above the staff. The J. Gtr. (Jazz Guitar) part continues its melodic line with slurs and ties. The E. Bass (Electric Bass) part continues its bass line with slurs.

95

Perc.

J. Gtr.

E. Bass

Detailed description: This system covers measures 95 to 96. The Percussion part (Perc.) continues its rhythmic pattern. The J. Gtr. (Jazz Guitar) part continues its melodic line with slurs and ties. The E. Bass (Electric Bass) part continues its bass line with slurs.

96

Perc. J. Gtr. E. Bass FX 5

This system covers measures 96 and 97. The Percussion part features a consistent rhythmic pattern of eighth notes with 'x' marks above them. The J. Gtr. part has a melodic line with various chords and accidentals. The E. Bass part provides a steady bass line with some syncopation. The FX 5 part is mostly silent in measure 96 and begins in measure 97 with a series of eighth notes.

98

Perc. J. Gtr. E. Bass FX 5

This system covers measures 98 and 99. The Percussion part continues with the same eighth-note pattern. The J. Gtr. part has a melodic line with various chords and accidentals. The E. Bass part provides a steady bass line with some syncopation and a triplet of eighth notes in measure 99. The FX 5 part continues with a series of eighth notes.

99

Perc. J. Gtr. E. Bass FX 5

This system covers measures 99 and 100. The Percussion part continues with the same eighth-note pattern. The J. Gtr. part has a melodic line with various chords and accidentals. The E. Bass part provides a steady bass line with some syncopation. The FX 5 part continues with a series of eighth notes.

100

Perc. J. Gtr. E. Bass FX 5

This system contains measures 100, 101, and 102. The Percussion part features a consistent rhythmic pattern of eighth notes with 'x' marks above them. The J. Gtr. part has a melodic line with a key signature of one sharp (F#) and a mix of eighth and quarter notes. The E. Bass part provides a steady bass line with eighth notes and rests. The FX 5 part has a melodic line with eighth notes and rests.

101

Perc. J. Gtr. E. Bass FX 5

This system contains measures 103, 104, and 105. The Percussion part continues with eighth notes and 'x' marks. The J. Gtr. part has a more complex melodic line with some triplets and slurs. The E. Bass part has a steady bass line with eighth notes and rests. The FX 5 part has a melodic line with eighth notes and rests.

103

Perc. E. Bass A.

This system contains measures 106, 107, and 108. The Percussion part has a rhythmic pattern of eighth notes with 'x' marks. The E. Bass part has a steady bass line with eighth notes and rests. The A. part has a melodic line with eighth notes and rests.

105

Perc. E. Bass A.

This system contains measures 105 and 106. The Percussion part features a complex rhythmic pattern with eighth and sixteenth notes. The Electric Bass part has a melodic line with eighth notes and some accidentals. The Acoustic guitar part consists of a series of chords, including a D major chord and a G major chord.

107

Perc. E. Bass A.

This system contains measures 107 and 108. The Percussion part continues with a similar rhythmic pattern. The Electric Bass part has a melodic line with eighth notes and some accidentals. The Acoustic guitar part consists of a series of chords, including a D major chord and a G major chord.

109

Perc. E. Bass A.

This system contains measures 109 and 110. The Percussion part continues with a similar rhythmic pattern. The Electric Bass part has a melodic line with eighth notes and some accidentals. The Acoustic guitar part consists of a series of chords, including a D major chord and a G major chord.

111

Perc. E. Bass A.

This system contains measures 111 and 112. The Percussion part features a complex rhythmic pattern with eighth and sixteenth notes. The Electric Bass part has a melodic line with eighth notes and some accidentals. The Acoustic part consists of a series of chords, primarily triads, with some accidentals.

113

Perc. E. Gtr. E. Bass FX 5

This system contains measures 113 and 114. The Percussion part has a steady eighth-note pattern. The Electric Guitar part features a series of chords, some with accidentals. The Electric Bass part has a melodic line with eighth notes. The FX 5 part consists of a series of chords, some with accidentals.

115

Perc. E. Gtr. E. Bass FX 5

This system contains measures 115 and 116. The Percussion part has a steady eighth-note pattern. The Electric Guitar part features a series of chords, some with accidentals. The Electric Bass part has a melodic line with eighth notes. The FX 5 part consists of a series of chords, some with accidentals.

117

Perc. E. Gtr. E. Bass FX 5

This system contains measures 117 and 118. The Percussion part features a consistent rhythmic pattern of eighth notes with 'x' marks above them. The Electric Guitar part plays a sequence of eighth notes, starting with a sharp sign and ending with a natural sign. The Electric Bass part plays a steady eighth-note line. The FX 5 part has a melodic line with various accidentals and rests.

119

Perc. E. Gtr. E. Bass FX 5

This system contains measures 119 and 120. The Percussion part continues with the same eighth-note pattern. The Electric Guitar part plays a sequence of eighth notes, including a sharp sign. The Electric Bass part continues with its eighth-note line. The FX 5 part has a melodic line with various accidentals and rests.

121

Perc. E. Gtr. E. Bass FX 5

This system contains measures 121 and 122. The Percussion part continues with the eighth-note pattern, including some 'x' marks with asterisks. The Electric Guitar part plays a sequence of chords, indicated by vertical lines and notes. The Electric Bass part continues with its eighth-note line. The FX 5 part has a melodic line with various accidentals and rests.

123

Perc.

E. Gtr.

E. Bass

125

Perc.

E. Gtr.

E. Bass

127

Perc.

E. Gtr.

E. Gtr.

E. Bass

129

Perc.



E. Gtr.

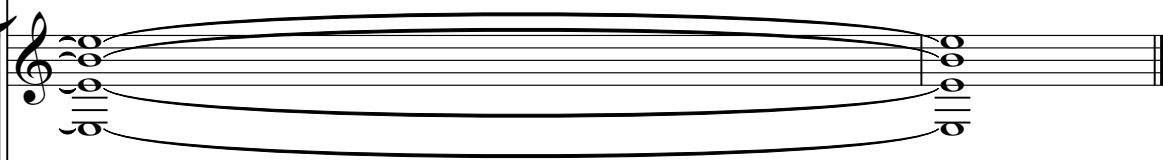

E. Gtr.

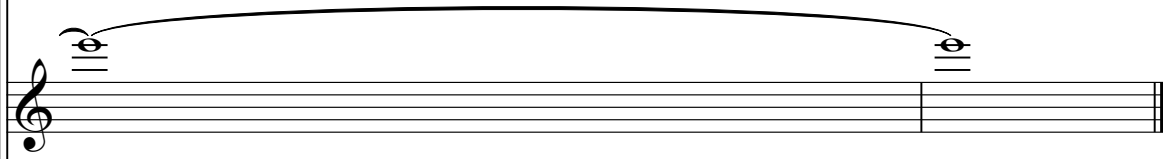

E. Bass

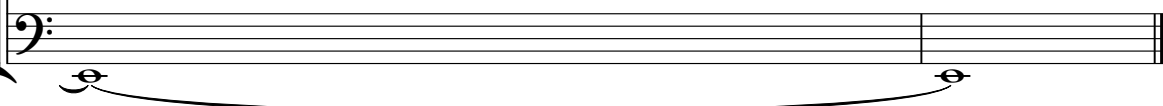

Detailed description: This musical score page features four staves. The top staff is for Percussion, showing a sequence of rhythmic patterns with 'x' marks for hits and slanted lines for accents, including three triplet markings. The second staff is for Electric Guitar (E. Gtr.) in treble clef, showing a long, sustained chord with a slur over it. The third staff is also for Electric Guitar (E. Gtr.) in treble clef, showing a long, sustained chord with a slur. The bottom staff is for Electric Bass (E. Bass) in bass clef, showing a long, sustained chord with a slur.

Percussion

♩ = 145,000031

2

6

9

11

13

15

17

20

22

24

3

V.S.

Percussion

26

28

30

32

34

36

38

40

42

44

46

48

50

52

54

56

58

60

62

64

V.S.

Musical score for Percussion, measures 66-86. The score is written on two staves per system. The top staff uses a treble clef and contains rhythmic notation with 'x' marks above notes, indicating specific percussion sounds. The bottom staff uses a bass clef and contains rhythmic notation with dots and 'x' marks below notes, indicating other percussion sounds. The measures are numbered 66, 68, 71, 73, 76, 78, 80, 82, 84, and 86. The notation includes various rhythmic patterns such as eighth notes, sixteenth notes, and dotted notes, often grouped with beams and 'x' marks to indicate specific percussive effects.

Percussion

88

Two staves of music. The top staff contains rhythmic notation with 'x' marks above notes, indicating a specific percussive sound. The bottom staff contains a bass line with notes and rests.

90

Two staves of music. The top staff contains rhythmic notation with 'x' marks above notes. The bottom staff contains a bass line with notes and rests.

92

Two staves of music. The top staff contains rhythmic notation with 'x' marks above notes. The bottom staff contains a bass line with notes and rests.

94

Two staves of music. The top staff contains rhythmic notation with 'x' marks above notes and a triplet bracket over three notes. The bottom staff contains a bass line with notes and rests.

96

Two staves of music. The top staff contains rhythmic notation with 'x' marks above notes. The bottom staff contains a bass line with notes and rests.

98

Two staves of music. The top staff contains rhythmic notation with 'x' marks above notes. The bottom staff contains a bass line with notes and rests.

100

Two staves of music. The top staff contains rhythmic notation with 'x' marks above notes. The bottom staff contains a bass line with notes and rests.

102

Two staves of music. The top staff contains rhythmic notation with 'x' marks above notes. The bottom staff contains a bass line with notes and rests.

105

Two staves of music. The top staff contains rhythmic notation with 'x' marks above notes. The bottom staff contains a bass line with notes and rests.

108

Two staves of music. The top staff contains rhythmic notation with 'x' marks above notes. The bottom staff contains a bass line with notes and rests.

V.S.

111

Measure 111: Two staves. The top staff contains a sequence of eighth notes with stems pointing up. The bottom staff contains a sequence of eighth notes with stems pointing down, alternating with rests.

114

Measure 114: Two staves. The top staff contains a sequence of eighth notes with stems pointing up, marked with an asterisk. The bottom staff contains a sequence of eighth notes with stems pointing up.

116

Measure 116: Two staves. The top staff contains a sequence of eighth notes with stems pointing up. The bottom staff contains a sequence of eighth notes with stems pointing up.

118

Measure 118: Two staves. The top staff contains a sequence of eighth notes with stems pointing up. The bottom staff contains a sequence of eighth notes with stems pointing up.

120

Measure 120: Two staves. The top staff contains a sequence of eighth notes with stems pointing up. The bottom staff contains a sequence of eighth notes with stems pointing up.

122

Measure 122: Two staves. The top staff contains a sequence of eighth notes with stems pointing up, marked with an asterisk. The bottom staff contains a sequence of eighth notes with stems pointing up.

124

Measure 124: Two staves. The top staff contains a sequence of eighth notes with stems pointing up, marked with an asterisk. The bottom staff contains a sequence of eighth notes with stems pointing up, including a triplet of eighth notes.

127

Measure 127: Two staves. The top staff contains a sequence of eighth notes with stems pointing up, grouped into triplets. The bottom staff contains a sequence of eighth notes with stems pointing up.

129

Measure 129: Two staves. The top staff contains a sequence of eighth notes with stems pointing up, grouped into triplets. The bottom staff contains a sequence of eighth notes with stems pointing up, including a triplet of eighth notes.

♩ = 145,000031

3

5

7

9

11

14

16

18

20

22

24

26

28

30

40

42

44

46

48

Jazz Guitar

3

50

52

54

56

66

68

70

72

74

76

85

88

90

92

94

96

98

100

102

♩ = 145,000031

30

35

37

39

18

61

63

12

77

82

84

28

The musical score is written for electric guitar in 4/4 time. It consists of nine staves of music. The first staff (measures 30-34) features a series of chords: a whole rest, a D major chord, an E major chord, a D major chord, and an E major chord. The second staff (measures 35-36) contains a rhythmic pattern of eighth notes with a key signature of one sharp (F#). The third staff (measures 37-38) continues this rhythmic pattern with a mix of eighth and sixteenth notes. The fourth staff (measures 39-43) features a series of chords: a whole rest, a D major chord, an E major chord, a D major chord, and an E major chord. The fifth staff (measures 61-62) continues the eighth-note rhythmic pattern. The sixth staff (measures 63-76) features a complex rhythmic pattern with many sixteenth notes, ending with a whole rest. The seventh staff (measures 77-81) features a series of chords: a D major chord, an E major chord, a D major chord, and an E major chord. The eighth staff (measures 82-83) continues the eighth-note rhythmic pattern. The ninth staff (measures 84-91) features a series of chords: a D major chord, an E major chord, a D major chord, and an E major chord.

113

Musical notation for guitar, measures 113-116. The notation is on a single staff in treble clef. Measure 113 starts with a treble clef and a key signature of one sharp (F#). It contains a sequence of eighth notes with slurs and accents, followed by a sixteenth-note triplet. Measure 114 continues the eighth-note pattern. Measure 115 features a sixteenth-note triplet. Measure 116 consists of four chords: a D major chord, an E major chord with a sharp sign, a D major chord, and a C major chord with a flat sign.

117

Musical notation for guitar, measures 117-120. The notation is on a single staff in treble clef. Measure 117 begins with a treble clef and a key signature of two sharps (F# and C#). It contains a sequence of eighth notes with slurs and accents. Measure 118 continues the eighth-note pattern. Measure 119 continues the eighth-note pattern. Measure 120 consists of four chords: a D major chord with a sharp sign, a C major chord with a sharp sign, a D major chord, and a C major chord.

119

Musical notation for guitar, measures 119-122. The notation is on a single staff in treble clef. Measure 119 begins with a treble clef and a key signature of two sharps (F# and C#). It contains a sequence of eighth notes with slurs and accents. Measure 120 continues the eighth-note pattern. Measure 121 continues the eighth-note pattern. Measure 122 consists of four chords: a D major chord, a C major chord with a sharp sign, a D major chord, and a C major chord.

122

Musical notation for guitar, measures 122-125. The notation is on a single staff in treble clef. Measure 122 begins with a treble clef and a key signature of two sharps (F# and C#). It contains a sequence of chords: a D major chord, a C major chord with a sharp sign, a D major chord, and a C major chord. Measure 123 continues the chord sequence. Measure 124 continues the chord sequence. Measure 125 consists of four chords: a D major chord, a C major chord with a sharp sign, a D major chord, and a C major chord.

♩ = 145,000031

126

4/4

♩ = 145,000031

8



12



15



18



21



24



27



30



34



38



V.S.

41



44



47



50



53



56



60



64



68



72



75

78

82

86

89

92

95

98

101

104

V.S.

107



110



113



117



121



124

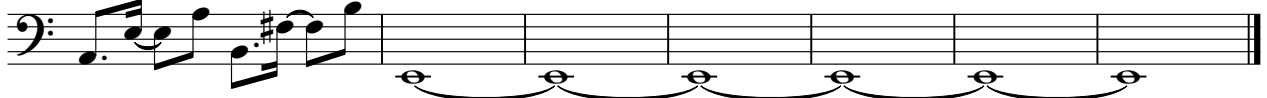

Alto

♩ = 145,000031

102

♩ = 145,000031

16

18

20

3

25

27

29

33

36

38

3

Detailed description: The image shows a musical score for guitar in 4/4 time. It consists of nine staves of music. The first staff starts with a tempo marking of ♩ = 145,000031 and a measure rest for 16 measures. The second staff begins at measure 18. The third staff has a measure rest for 3 measures starting at measure 20. The fourth staff starts at measure 25. The fifth staff starts at measure 27. The sixth staff starts at measure 29. The seventh staff starts at measure 33. The eighth staff starts at measure 36. The ninth staff has a measure rest for 3 measures starting at measure 38. The music features various rhythmic patterns, including eighth and sixteenth notes, and includes several accidentals (sharps and naturals).

43

45

48

3

53

56

59

62

64

11

77

80

83



86

3



91



94

3



99



102

11



115



118



120

9

