

Barry White - Never

00:00:02:22
2.1,00
Intro

♩ = 87,000023

The musical score is arranged in a vertical stack of staves. From top to bottom, the instruments are: Flute, Alto Saxophone, Percussion, Vibraphone, Jazz Guitar, Electric Bass, 5-string Electric Bass, Alto, FM Synth, FX 5 (Brightness), and Viola. The key signature is B-flat major (two flats) and the time signature is 4/4. The tempo is marked as ♩ = 87,000023. The score shows the first two measures of the piece. The FM Synth part begins in the second measure with a complex melodic line. The Electric Bass staff has some faint markings: 'res.' and 'p' in the first measure, and 'p' in the second measure. The Viola staff is empty.

(C) 1998 by M-LIVE s.r.l.;Ed. Warner Chappell Music Italiana
(C) 1998 by M-LIVE s.r.l.;Ed. Warner Chappell Music Italiana

3

Perc. 

Vib. 

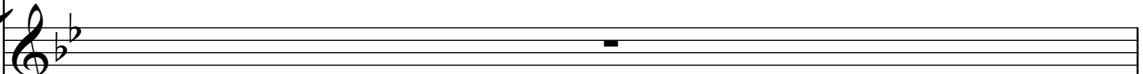
J. Gtr. 

MA KE LOVE TO YOU RIGHT NOW THAT ALL

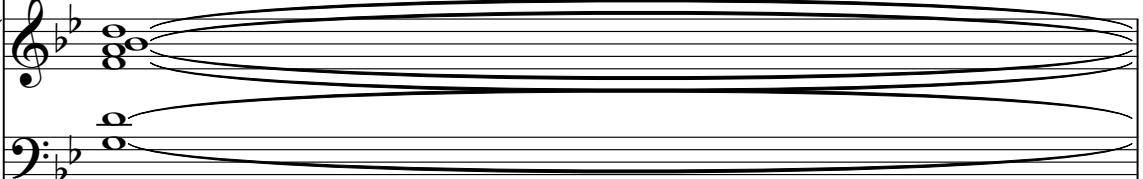
FM 



4

Perc. 

Vib. 

J. Gtr. 

I WANT TO DO

FM 

5

Perc. 

Vib. 

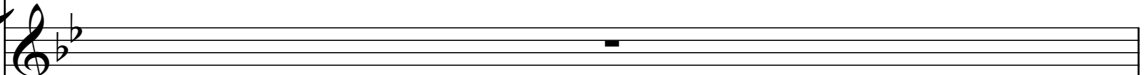
J. Gtr. 

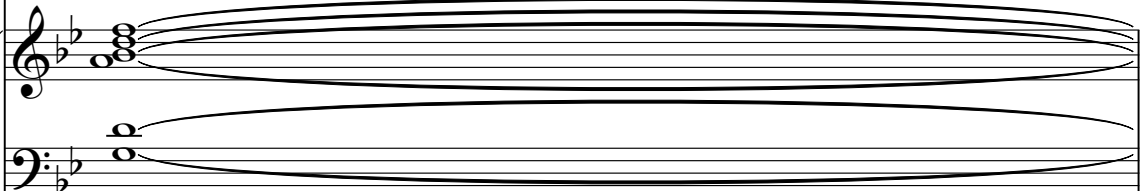
FM 

I KNOW YOU NEED IT GIRL AND YOU



6

Perc. 

Vib. 

J. Gtr. 

E. Bass 

FM 

Vla. 

KNOW I NEED IT TOO CAUSE

6

7

Perc.

Vib.

J. Gtr.

'VE FOUND WHAT THE WORLD

E. Bass

E. Bass

FM

Vla.

8

Perc.

Vib.

J. Gr.

E. Bass

E. Bass

FM

Vla.

IS SEAR CHIN FOR

The musical score consists of six staves. The Percussion staff (Perc.) features a rhythmic pattern of eighth notes with accents. The Vibraphone staff (Vib.) has a melodic line with grace notes. The Jazz Guitar staff (J. Gr.) is mostly silent, with the lyrics 'IS SEAR CHIN FOR' written below it. The Electric Bass staff (E. Bass) has a simple bass line. The Fretless Bass staff (FM) plays a complex harmonic accompaniment. The Viola staff (Vla.) has a few scattered notes.

9

Perc.

Vib.

J. Gtr.

E. Bass

E. Bass

A.

FM

Vla.

NE VER E VER GON NA GIVE YOU UP

10

Fl.

Perc.

Vib.

J. Gtr.

E. Bass

E. Bass

A.

FM

Vla.

IM NE VER EV ER GON NA STOP

Detailed description: This is a page of a musical score for a jazz ensemble. The score is written in B-flat major (two flats) and 4/4 time. It features eight staves: Flute (Fl.), Percussion (Perc.), Vibraphone (Vib.), J. Guitar (J. Gtr.), Electric Bass (E. Bass), Alto Saxophone (A.), Fiddle (FM), and Viola (Vla.). The Flute part starts at measure 10 and features two triplet eighth-note patterns. The Percussion part has a steady eighth-note accompaniment with accents. The Vibraphone part has a melodic line with eighth-note patterns. The J. Guitar part is mostly silent, with a few notes at the end of the phrase. The E. Bass part has a melodic line with eighth-note patterns. The A. part has a melodic line with eighth-note patterns. The FM part has a harmonic accompaniment with sustained chords. The Vla. part has a few notes at the beginning of the phrase. The lyrics 'IM NE VER EV ER GON NA STOP' are written below the J. Gtr. staff.

11

Fl.

Perc.

Vib.

J. Gtr.

E. Bass

E. Bass

FM

Vla.

'VE FOUND WHAT THE WORLD

Detailed description: This is a page of a musical score, page 8, starting at measure 11. The score is arranged in a grand staff format with seven systems of staves. The instruments are: Flute (Fl.), Percussion (Perc.), Vibraphone (Vib.), J. Guitar (J. Gtr.), Electric Bass (E. Bass), Fiddle/Double Bass (FM), and Viola (Vla.). The key signature has two flats (B-flat and E-flat), and the time signature is 4/4. The Flute part has a few notes in the first measure followed by rests. The Percussion part features a rhythmic pattern of eighth notes with accents. The Vibraphone part has a melodic line with some rests. The J. Guitar part is mostly silent, with some notes appearing in the second measure corresponding to the lyrics. The E. Bass part has a simple bass line. The FM part consists of chords. The Vla. part has a few notes in the first measure. The lyrics are: 'VE FOUND WHAT THE WORLD.

12

Perc.

Vib.

J. Gr.

E. Bass

E. Bass

FM

Vla.

IS SEAR CHIN FOR

The musical score consists of six staves. The Percussion staff (Perc.) features a rhythmic pattern of eighth notes with accents. The Vibraphone staff (Vib.) has a melodic line with grace notes. The Jazzy Guitar staff (J. Gr.) is mostly silent, with the lyrics 'IS SEAR CHIN FOR' written below it. The Electric Bass staff (E. Bass) has a simple bass line. The Fiddle (FM) and Viola (Vla.) staves have harmonic accompaniment. The score is in 4/4 time and the key signature has two flats.

13

Perc.

Vib.

J. Gtr.

E. Bass

E. Bass

A.

FM

Vla.

NE VER E VER GON NA GIVE YOU UP

14

Fl.

Perc.

Vib.

J. Gtr.

E. Bass

E. Bass

A.

FM

FX 5

Vla.

M NE VER E VER GON NA STOP WHAT

15

Fl.

Perc.

Vib.

J. Gtr.
E VER WHAT E VER

E. Bass

E. Bass

A.

FM

FX 5

16

Perc.

Vib.

J. Gtr.

E. Bass

E. Bass

A.

FM

FX 5

GIRL

I

17

Perc.

Vib.

J. Gtr.

E. Bass

E. Bass

A.

FM

FX 5

DO

Detailed description: This is a musical score for a multi-instrument ensemble. The score is written for seven parts: Percussion (Perc.), Vibraphone (Vib.), J. Gtr. (J. Gtr.), E. Bass (E. Bass), A. (A.), FM (FM), and FX 5 (FX 5). The music is in a key signature of two flats (B-flat and E-flat) and a 4/4 time signature. The Percussion part features a rhythmic pattern of eighth notes with accents. The Vibraphone part has a melodic line starting with a quarter note followed by eighth notes. The J. Gtr. part includes a melodic line with a 'DO' label under the first measure and some complex chordal textures. The E. Bass part has a melodic line with eighth notes. The A. part has a melodic line with eighth notes. The FM part consists of a sustained chord in the right hand and a single note in the left hand. The FX 5 part has a melodic line with eighth notes.

18

Perc.

Vib.

J. Gtr.

E. Bass

E. Bass

A.

FM

FX 5

FOR

Detailed description: This is a page of a musical score, page 15, starting at rehearsal mark 18. The score is arranged in a system with seven staves. The top staff is Percussion (Perc.), featuring a complex rhythmic pattern with eighth and sixteenth notes and rests. The second staff is Vibraphone (Vib.), showing a melodic line with rests and a final note. The third staff is J. Gtr. (Jazz Guitar), with a melodic line and a section labeled 'FOR' containing a guitar-specific notation. The fourth staff is E. Bass (Electric Bass), with a melodic line and a section labeled 'FOR' containing a guitar-specific notation. The fifth staff is another E. Bass line, featuring a rhythmic pattern of eighth notes. The sixth staff is A. (Alto Saxophone), with a melodic line. The seventh staff is FM (Fingered Mallets), with a melodic line. The eighth staff is FX 5 (Fingered Xylophone), with a melodic line. The key signature has two flats (B-flat and E-flat), and the time signature is 4/4.

19

Perc. Vib. J. Gtr. E. Bass E. Bass A. FM FX 5

E VER AND E VER YEAH YEAH YEAH YEAH

Detailed description: This is a multi-staff musical score for a jazz ensemble. The score is in 4/4 time and features a key signature of two flats (B-flat and E-flat). The instruments and their parts are: Percussion (Perc.) with a snare drum pattern; Vibraphone (Vib.) with a melodic line; J. Gtr. (Jazz Guitar) with a melodic line and lyrics 'E VER AND E VER YEAH YEAH YEAH YEAH'; E. Bass (Electric Bass) with a bass line; A. (Alto Saxophone) with a melodic line; FM (French Mellophone) with a sustained chord; and FX 5 (Effects) with a short melodic phrase. The score is numbered 19 at the beginning.

20

Perc. Vib. J. Gtr. E. Bass E. Bass A. FM FX 5

'LL SEE YOU

Detailed description: This is a multi-staff musical score for a jazz ensemble. The score includes parts for Percussion (Perc.), Vibraphone (Vib.), J. Guitar (J. Gtr.), Electric Bass (E. Bass), Alto Saxophone (A.), Fiddle (FM), and FX 5. The music is in a key with two flats (B-flat and E-flat) and a 4/4 time signature. The Percussion part features a complex rhythmic pattern with accents. The Vibraphone and Alto Saxophone parts have melodic lines with grace notes. The J. Guitar part includes a solo section with the lyrics "'LL SEE YOU". The Electric Bass parts provide a steady bass line. The Fiddle part has a melodic line with a long note. The FX 5 part has a melodic line with grace notes.

21

Perc.

Vib.

J. Gtr.

THROUGH

E. Bass

E. Bass

A.

FM

FX 5

Detailed description: This is a page of a musical score, page 18, starting at measure 21. The score is arranged in a grand staff format with seven staves. The top staff is for Percussion (Perc.), showing a rhythmic pattern of eighth notes with 'x' marks above them. The second staff is for Vibraphone (Vib.), with a few notes and rests. The third staff is for J. Gtr. (J. Gtr.), featuring a melodic line with a section labeled 'THROUGH' in all caps. The fourth staff is for Electric Bass (E. Bass), with a bass line. The fifth staff is another Electric Bass (E. Bass) part. The sixth staff is for Alto Saxophone (A.). The seventh staff is for Fiddle (FM), with a treble and bass clef. The eighth staff is for FX 5, with a few notes. The key signature has two flats (B-flat and E-flat), and the time signature is 4/4.

22

Fl.

Perc.

J. Gtr.

E. Bass

E. Bass

FM

FX 5

Detailed description: This musical score page, numbered 19, begins at measure 22. It features six staves. The Flute (Fl.) staff is in treble clef with a key signature of two flats (B-flat and E-flat), showing two triplet eighth-note patterns. The Percussion (Perc.) staff uses a snare drum symbol and shows a rhythmic pattern of eighth notes with 'x' marks above them. The J. Guitar (J. Gtr.) staff is in treble clef with a key signature of two flats, featuring a series of chords and rests. The first E. Bass staff is in bass clef with a key signature of two flats, showing a few notes and rests. The second E. Bass staff is in bass clef with a key signature of two flats, showing a continuous eighth-note line. The FM (Fingered Mandolin) staff is in treble clef with a key signature of two flats, showing a melodic line with a long slur. The FX 5 staff is in treble clef with a key signature of two flats, showing a series of chords and rests.

23

Fl.

Perc.

Vib.

J. Gtr.

E. Bass

E. Bass

FM

FX 5

Vla.

IL HAVE TO KEEP YOU PLEASED IN

24

Perc.

Vib.

J. Gtr.

E. Bass

E. Bass

FM

FX 5

Vla.

E VERY WAY I CAN

Detailed description: This is a page of a musical score for a jazz ensemble. It features seven staves. The Percussion staff (Perc.) has a drum set icon and a rhythmic pattern of eighth notes with 'x' marks. The Vibraphone (Vib.) staff has a treble clef and a melodic line with slurs. The J. Guitar (J. Gtr.) staff has a treble clef and contains the lyrics 'E VERY WAY I CAN' with notes and rests. The Electric Bass (E. Bass) staff has a bass clef and a simple bass line. The second Electric Bass staff has a bass clef and a more active bass line. The FM (French Mellophone) staff has a treble clef and sustained notes. The FX 5 (F5) staff has a treble clef and a few notes. The Viola (Vla.) staff has a bass clef and a few notes.

25

Perc.

Vib.

J. Gtr.

E. Bass

E. Bass

FM

FX 5

Vla.

GON NA GIVE YOU ALL OF ME AS

Detailed description: This is a page of a musical score, page 22, starting at measure 25. The score is arranged in a vertical stack of staves. From top to bottom, the staves are: Percussion (Perc.), Vibraphone (Vib.), J. Guitar (J. Gtr.), Electric Bass (E. Bass), another Electric Bass (E. Bass), FM (likely a French Horn or Flute), FX 5 (likely a Flute), and Viola (Vla.). The J. Gtr. staff contains the lyrics: "GON NA GIVE YOU ALL OF ME AS". The music is in a key with two flats (B-flat and E-flat) and a 4/4 time signature. The Percussion part features a rhythmic pattern of eighth notes with 'x' marks above them. The Vibraphone part has a melodic line with grace notes. The J. Guitar part has a melodic line with some accidentals. The Electric Bass parts have a rhythmic accompaniment. The FM part has a sustained chord. The FX 5 part has a melodic line. The Viola part has a sustained chord.

26

Perc.

Vib.

J. Gtr.

MUCH AS YOU CAN STAND

E. Bass

E. Bass

FM

FX 5

Vla.

Detailed description: This is a page of a musical score for a jazz ensemble. It features seven staves. The Percussion staff (Perc.) has a drum set icon and a rhythmic pattern of eighth notes with 'x' marks above them. The Vibraphone (Vib.) staff has a treble clef and a key signature of two flats, with a melodic line of eighth notes. The J. Gtr. (Jazz Guitar) staff has a treble clef and the lyrics 'MUCH AS YOU CAN STAND' written below it. The E. Bass (Electric Bass) staff has a bass clef and a melodic line. The FM (Fingered Mandolin) staff has a treble clef and a melodic line with slurs. The FX 5 (Fingered Xylophone) staff has a treble clef and a melodic line. The Vla. (Viola) staff has a bass clef and a key signature of two flats, with a few notes at the beginning of the staff.

27

Perc.

Vib.

J. Gtr.

E. Bass

E. Bass

FM

FX 5

Vla.

MA KE LOVE TO YOU RIGHT NOW THAT ALL

Detailed description: This is a page of a musical score for a jazz ensemble. It features seven staves. The Percussion staff (Perc.) has a drum set icon and a rhythmic pattern of eighth notes with 'x' marks. The Vibraphone (Vib.) staff has a treble clef and a melodic line. The J. Guitar (J. Gtr.) staff has a treble clef and a melodic line with lyrics: 'MA KE LOVE TO YOU RIGHT NOW THAT ALL'. The first Electric Bass (E. Bass) staff has a bass clef and a simple bass line. The second Electric Bass (E. Bass) staff has a bass clef and a more active bass line. The FM (French Mellophone) staff has a treble clef and a sustained chord. The FX 5 (FX 5) staff has a treble clef and a melodic line. The Viola (Vla.) staff has a bass clef and a melodic line. The score is in 4/4 time and the key signature has two flats.

28

Perc.

Vib.

J. Gtr.

I WANT TO DO

E. Bass

E. Bass

FM

FX 5

Vla.

29

Perc.

Vib.

J. Gtr.

I KNOW YOU NEED IT GIRL AND YOU

E. Bass

E. Bass

FM

FX 5

Vla.

Detailed description: This is a page of a musical score for a jazz ensemble. It features seven staves. The top staff is for Percussion (Perc.), showing a rhythmic pattern of eighth notes with accents. The second staff is for Vibraphone (Vib.), with a melodic line in B-flat major. The third staff is for J. Guitar (J. Gtr.), which includes the lyrics 'I KNOW YOU NEED IT GIRL AND YOU' and a melodic line. The fourth staff is for Electric Bass (E. Bass), showing a bass line. The fifth staff is another Electric Bass (E. Bass) part. The sixth staff is for FM (French Mellophone), showing a sustained chord. The seventh staff is for FX 5 (F5), showing a melodic line. The eighth staff is for Viola (Vla.), showing a sustained chord. The score is in 4/4 time and B-flat major.

30

Fl.

Perc.

Vib.

J. Gtr.

E. Bass

E. Bass

FM

FX 5

Vla.

KNOW I NEED IT TOO CAUSE

31

Fl.

Perc.

Vib.

J. Gtr.

E. Bass

E. Bass

FM

FX 5

Vla.

'VE FOUND WHAT THE WORLD

32

Perc. Vib. J. Gtr. E. Bass E. Bass FM FX 5 Vla.

IS SEAR CHIN FOR

Detailed description: This is a page of a musical score for a jazz ensemble. It features seven staves. The top staff is Percussion (Perc.), showing a rhythmic pattern with eighth notes and rests. The second staff is Vibraphone (Vib.), with a melodic line in 4/4 time. The third staff is J. Guitar (J. Gtr.), which includes lyrics: "IS SEAR CHIN FOR". The fourth staff is Electric Bass (E. Bass), showing a bass line. The fifth staff is another Electric Bass (E. Bass) part. The sixth staff is Fiddle (FM), with a melodic line. The seventh staff is FX 5, with a melodic line. The eighth staff is Viola (Vla.), with a melodic line. The score is in a key with two flats and 4/4 time.

33

Perc. Vib. J. Gtr. E. Bass E. Bass FM FX 5 Vla.

HERE RIGHT HERE MY DEAR

Detailed description: This is a page of a musical score, page 30, starting at measure 33. The score is arranged in a grand staff with seven staves. The top staff is Percussion (Perc.), featuring a rhythmic pattern of eighth notes with 'x' marks above them. The second staff is Vibraphone (Vib.), with a melodic line starting on a dotted quarter note and followed by eighth notes. The third staff is J. Guitar (J. Gtr.), which includes the lyrics 'HERE', 'RIGHT HERE', 'MY', and 'DEAR' under the notes. The fourth staff is Electric Bass (E. Bass), showing a simple bass line. The fifth staff is another Electric Bass (E. Bass) part with a more active line. The sixth staff is FM (Fingered Music), consisting of two staves with chords. The seventh staff is FX 5 (Effects), with some initial notes and rests. The eighth staff is Viola (Vla.), with a sustained chord and a hairpin crescendo.

34

Perc.

Vib.

J. Gtr.

I DON'T HAVE TO LOOK NO MORE

E. Bass

E. Bass

FM

FX 5

Vla.

Detailed description: This is a page of a musical score for a jazz ensemble. It features seven staves. The Percussion staff (Perc.) has a drum set icon and a rhythmic pattern of eighth notes with 'x' marks above them. The Vibraphone (Vib.) staff has a treble clef and a melodic line with slurs. The J. Gtr. (Jazz Guitar) staff has a treble clef and a melodic line with lyrics 'I DON'T HAVE TO LOOK NO MORE' written below it. The E. Bass (Electric Bass) staff has a bass clef and a rhythmic line. The FM (Fingered Mallets) staff has a grand staff with treble and bass clefs and a sustained chord. The FX 5 (Effects) staff has a treble clef and a few notes. The Vla. (Violoncello) staff has a bass clef and a sustained note. The page number '34' is at the top left, and '31' is at the top right.

35

Perc.

Vib.

J. Gtr.

E. Bass

E. Bass

FM

FX 5

Vla.

AND ALL MY DAYS

Detailed description: This is a page of a musical score, page 32, starting at measure 35. The score is arranged in a grand staff with seven staves. The top staff is Percussion (Perc.), featuring a rhythmic pattern of eighth notes with 'x' marks above them. The second staff is Vibraphone (Vib.), with a melodic line of eighth notes. The third staff is J. Guitar (J. Gtr.), which includes the lyrics 'AND ALL MY DAYS' under the notes. The fourth staff is Electric Bass (E. Bass), showing a bass line with eighth notes. The fifth staff is another Electric Bass (E. Bass) part with a similar rhythmic pattern. The sixth staff is FM (Fingered Mandolin), with a few notes in the treble clef. The seventh staff is FX 5 (Fingered Xylophone), with a few notes in the treble clef. The eighth staff is Viola (Vla.), with a few notes in the bass clef. The key signature has two flats (B-flat and E-flat), and the time signature is 4/4.

36

Perc.

Vib.

J. Gtr.

E. Bass

E. Bass

FM

FX 5

Vla.

ID HOPED AND ID PRAYED:

Detailed description: This page of a musical score, numbered 33 at the top right and 36 at the top left, features seven staves. The Percussion staff (Perc.) uses a snare drum and tom-tom symbols. The Vibraphone (Vib.) and J. Guitar (J. Gtr.) staves are in treble clef with a key signature of two flats. The J. Gtr. staff includes the lyrics "ID HOPED AND ID PRAYED:" under the notes. The Electric Bass (E. Bass) staves are in bass clef. The FM (Fingered Mallet) staff is in treble clef. The FX 5 (Fingered Xylophone) staff is in treble clef. The Viola (Vla.) staff is in alto clef. The score shows various rhythmic patterns and melodic lines for each instrument.

37

Perc.

Vib.

J. Gtr.

E. Bass

FM

FX 5

Vla.

FOR SOME ONE JUST LIKE YOU

38

Perc.

Vib.

J. Gtr.
MAKE ME FEEL THE WAY YOU DO

E. Bass

E. Bass

FM

FX 5

Vla.

Detailed description: This is a page of a musical score for a jazz ensemble. It features seven staves. The top staff is for Percussion (Perc.), showing a rhythmic pattern with accents. The second staff is for Vibraphone (Vib.), with a melodic line. The third staff is for J. Gtr. (Jazz Guitar), which includes the lyrics 'MAKE ME FEEL THE WAY YOU DO' and a melodic line. The fourth staff is for E. Bass (Electric Bass), showing a simple bass line. The fifth staff is another E. Bass staff, providing a more complex bass line. The sixth staff is for FM (French Mellophone), with a melodic line. The seventh staff is for FX 5 (Fifth Saxophone), with a melodic line. The eighth staff is for Vla. (Violin), with a melodic line. The score is in a key with two flats and a 4/4 time signature.

39

Perc.

Vib.

J. Gtr.

E. Bass

E. Bass

A.

FM

Vla.

NE VER E VER GON NA GIVE YOU UP

40

Perc. Vib. J. Gtr. E. Bass E. Bass A. FM Vla.

IM NE VER E VER GON NA STOP

Detailed description: This is a page of a musical score for a jazz ensemble. It features six staves. The top staff is for Percussion (Perc.), showing a rhythmic pattern of eighth notes with accents. The second staff is for Vibraphone (Vib.), with a melodic line. The third staff is for Jazz Guitar (J. Gtr.), featuring chords and a melodic line with lyrics: "IM NE VER E VER GON NA STOP". The fourth and fifth staves are for Electric Bass (E. Bass), with a rhythmic bass line. The sixth staff is for Alto Saxophone (A.), with a melodic line. The seventh and eighth staves are for French Horn (FM), with a melodic line. The ninth staff is for Viola (Vla.), with a melodic line. The score is in 4/4 time and the key signature has two flats.

41

Perc.

Vib.

J. Gtr.

E. Bass

E. Bass

FM

Vla.

NOW THE WAY I FEEL A BOUT YOU

42

Perc.

Vib.

J. Gtr.

E. Bass

E. Bass

FM

Vla.

GIRL I JUST CAN LIVE WITH OUT YOU

The musical score for page 39, starting at measure 42, is arranged in a vertical staff format. The instruments and their parts are as follows:

- Perc.**: Features a rhythmic pattern of eighth notes with accents and rests.
- Vib.**: Plays a melodic line with eighth notes and rests.
- J. Gtr.**: Provides harmonic accompaniment with chords and includes the lyrics "GIRL I JUST CAN LIVE WITH OUT YOU".
- E. Bass** (top): Plays a bass line with eighth notes and rests.
- E. Bass** (bottom): Plays a bass line with eighth notes and rests.
- FM** (Fiddle): Plays a melodic line with long notes and rests.
- Vla.** (Viola): Plays a complex melodic line with a triplet at the end.

43

Perc.

Vib.

J. Gtr.

E. Bass

E. Bass

A.

FM

Vla.

IM NE VER E VER GON NA QUIT CAUSE

Detailed description: This is a page of a musical score for a jazz ensemble. It features seven staves. The Percussion staff (Perc.) has a complex rhythmic pattern with various notes and rests. The Vibraphone (Vib.) and J. Guitar (J. Gtr.) parts are in a 4/4 time signature with a key signature of two flats. The J. Gtr. part includes lyrics: "IM NE VER E VER GON NA QUIT CAUSE". The E. Bass part has a simple bass line. The A. (Alto Saxophone) part has a melodic line. The FM (French Horn) part has a sustained chord. The Vla. (Violoncello) part has a melodic line.

44

Perc.

Vib.

J. Gtr.

QUIT TIN JUST AIN MY STICK.

E. Bass

E. Bass

A.

FM

Vla.

Detailed description: This is a page of a musical score for a jazz ensemble. It features seven staves. The Percussion staff (Perc.) has a rhythmic pattern of eighth notes with accents. The Vibraphone (Vib.) and J. Gtr. (J. Guitar) parts are in the key of B-flat major. The J. Gtr. part includes the lyrics 'QUIT TIN JUST AIN MY STICK.' and features a melodic line with some double stops. The E. Bass (Electric Bass) part has a walking bass line. The A. (Alto Saxophone) part has a melodic line. The FM (French Horn) part has a melodic line with some sustained notes. The Vla. (Viola) part has a melodic line with some sustained notes. The score is in 4/4 time and includes various musical notations such as accents, slurs, and ties.

45

Perc.

Vib.

J. Gtr.

E. Bass

E. Bass

FM

Vla.

~~WON~~ STAY RIGHT HERE WITH YOU AND

46

Perc.

Vib.

J. Gtr.
DO IT THE THINGS YOU WANT ME TO WHAT

E. Bass

E. Bass

FM

FX 5

Vlna.

Detailed description: This is a page of a musical score for a jazz ensemble. It features seven staves. The Percussion staff (Perc.) has a drum set icon and a rhythmic pattern of eighth notes with accents. The Vibraphone (Vib.) staff has a treble clef and a melodic line with eighth notes and slurs. The J. Gtr. (Jazz Guitar) staff has a treble clef and chordal accompaniment, with lyrics 'DO IT THE THINGS YOU WANT ME TO WHAT' written below it. The E. Bass (Electric Bass) staff has a bass clef and a simple bass line. The FM (French Mellophone) staff has a treble clef and a melodic line with a long slur. The FX 5 (Fifth String) staff has a treble clef and a few notes. The Vlna. (Violina) staff has a bass clef and a melodic line with a triplet. The key signature has two flats (B-flat and E-flat), and the time signature is 4/4.

00:02:06:23
47.1,00
Verse 4

47

Perc.

Vib.

J. Gtr.

E. Bass

E. Bass

FM

FX 5

Vla.

E VER YOU WANT

Detailed description of the musical score: The score is for measures 47-50 of Verse 4. It features six staves. The Percussion staff (Perc.) has a drum set icon and shows a pattern of eighth notes with 'x' marks, indicating cymbal hits. The Vibraphone staff (Vib.) has a treble clef and shows a melodic line of eighth notes. The J. Guitar staff (J. Gtr.) has a treble clef and shows a melodic line with lyrics 'E VER YOU WANT' underneath. The Electric Bass staff (E. Bass) has a bass clef and shows a rhythmic pattern of eighth notes. The Fiddle staff (FM) has a treble clef and shows a sustained chord. The FX 5 staff has a treble clef and shows a melodic line with a fermata. The Viola staff (Vla.) has a bass clef and shows a sustained chord with a fermata.

48

Perc.

Vib.

J. Gtr.

E. Bass

E. Bass

A.

FM

FX 5

Vla.

GIRL

YOU

Detailed description: This is a page of a musical score for a jazz ensemble. It features eight staves. The Percussion staff (Perc.) has a drum set icon and a rhythmic pattern of eighth notes with 'x' marks above them. The Vibraphone (Vib.) staff has a treble clef and a melodic line with grace notes. The J. Guitar (J. Gtr.) staff has a treble clef and contains the lyrics 'GIRL' and 'YOU' with corresponding chords. The E. Bass staff (top) has a bass clef and contains the lyrics 'GIRL' and 'YOU' with corresponding chords. The E. Bass staff (bottom) has a bass clef and a rhythmic line. The A. (Alto Saxophone) staff has a treble clef and a melodic line. The FM (French Horn) staff has a treble clef and a melodic line. The FX 5 (Flute) staff has a treble clef and a melodic line. The Vla. (Violin) staff has a treble clef and a melodic line. The key signature is two flats (B-flat and E-flat), and the time signature is 4/4. The page number '48' is at the top left, and '45' is at the top right.

49

Perc. Vib. J. Gtr. E. Bass E. Bass A. FM FX 5 Vla.

GOT IT YOU

Detailed description: This is a page of a musical score, page 46, starting at measure 49. The score is arranged in a vertical stack of staves. From top to bottom, the staves are: Percussion (Perc.), Vibraphone (Vib.), J. Guitar (J. Gtr.), Electric Bass (E. Bass), another Electric Bass (E. Bass), Alto Saxophone (A.), Fiddle (FM), FX 5, and Viola (Vla.). The J. Gtr. staff includes the lyrics 'GOT IT YOU'. The music is in a key signature of two flats (B-flat and E-flat) and a 4/4 time signature. The Perc. part features a rhythmic pattern of eighth notes with accents. The Vib. part has a melodic line with some rests. The J. Gtr. part has a melodic line with some rests and a double bar line. The E. Bass parts have a rhythmic pattern of eighth notes. The A. part has a melodic line with some rests. The FM part has a sustained chord. The FX 5 part has a melodic line with some rests. The Vla. part has a melodic line with some rests.

50

Fl.

Perc.

Vib.

J. Gtr.

E. Bass

E. Bass

A.

FM

FX 5

Vla.

GOT IT WHAT

Detailed description: This is a page of a musical score for measures 50 through 53. The score is written for a variety of instruments: Flute (Fl.), Percussion (Perc.), Vibraphone (Vib.), J. Guitar (J. Gtr.), Electric Bass (E. Bass), Alto Saxophone (A.), Fiddle (FM), FX 5, and Viola (Vla.). The music is in a key with two flats (B-flat and E-flat) and a 4/4 time signature. Measure 50 starts with a treble clef and a key signature of two flats. The Flute part features a triplet of eighth notes in measures 51 and 52. The Percussion part has a steady eighth-note pattern with 'x' marks above some notes. The Vibraphone part has a simple eighth-note line. The J. Guitar part has lyrics 'GOT IT' in measures 51 and 52, and 'WHAT' in measure 53. The Electric Bass part has a simple eighth-note line. The Alto Saxophone part has a simple eighth-note line. The Fiddle part has a simple eighth-note line. The FX 5 part has a simple eighth-note line. The Viola part has a simple eighth-note line. The score is written in a standard musical notation style with various clefs and time signatures.

51

Fl.

Perc.

Vib.

J. Gtr.
E VER YOU NEED

E. Bass

E. Bass

A.

FM

FX 5

Vla.

52

Perc.

Vib.

J. Gtr.

E. Bass

E. Bass

A.

FM

FX 5

Vla.

I DON WAN NA SEE YOU WITH OUT

Detailed description: This is a page of a musical score for a jazz ensemble. The page is numbered 52 at the top left and 49 at the top right. The score consists of nine staves. The Percussion staff (Perc.) has a drum set icon and contains a rhythmic pattern of eighth notes with 'x' marks above them. The Vibraphone staff (Vib.) is in treble clef with a key signature of two flats and contains a melodic line. The J. Guitar staff (J. Gtr.) is in treble clef with a key signature of two flats and contains chords and a melodic line. The E. Bass staff (E. Bass) is in bass clef with a key signature of two flats and contains a bass line. The A. staff (A.) is in treble clef with a key signature of two flats and contains a melodic line. The FM staff (FM) is in grand staff (treble and bass clefs) with a key signature of two flats and contains a piano accompaniment. The FX 5 staff (FX 5) is in treble clef with a key signature of two flats and contains a melodic line. The Vla. staff (Vla.) is in bass clef with a key signature of two flats and contains a melodic line. The lyrics 'I DON WAN NA SEE YOU WITH OUT' are written across the J. Gtr. and E. Bass staves.

53

Perc.

Vib.

J. Gtr.

E. Bass

E. Bass

A.

FM

FX 5

Vla.

IT

Detailed description of the musical score: The score is for a multi-instrument ensemble. It begins at measure 53. The Percussion part features a rhythmic pattern of eighth notes with accents. The Vibraphone part has a melodic line with a rest. The J. Gtr. part includes a rest followed by a melodic phrase with a guitar tablature section. The E. Bass part has a melodic line with a rest. The A. part has a melodic line with a rest. The FM part has a sustained chord. The FX 5 part has a melodic line with a rest. The Vla. part has a melodic line with a rest.

54

Fl.

Perc.

J. Gtr.

E. Bass

E. Bass

FM

FX 5

Vla.

55

Fl.

Perc.

Vib.

J. Gtr.

E. Bass

E. Bass

FM

FX 5

Vla.

YOU GIVEN ME MUCH MORE THAN

Detailed description: This is a multi-staff musical score for Verse 5. The score includes parts for Flute (Fl.), Percussion (Perc.), Vibraphone (Vib.), J. Guitar (J. Gtr.), Electric Bass (E. Bass), FM (likely a second bass or keyboard), FX 5 (likely a second guitar), and Viola (Vla.). The J. Gtr. part includes the lyrics: "YOU GIVEN ME MUCH MORE THAN". The music is written in a key with two flats and a 4/4 time signature. The score is numbered 55 at the beginning of the first staff.

56

Perc. Vib. J. Gtr. E. Bass E. Bass FM FX 5 Vla.

WORDS COULD E VERY SAY AND

Detailed description: This is a page of a musical score for a jazz ensemble. The page is numbered 56 at the top left and 53 at the top right. The score consists of seven staves. The Percussion staff (Perc.) has a drum set icon and a rhythmic pattern of eighth notes with 'x' marks. The Vibraphone staff (Vib.) has a treble clef and a melodic line. The J. Gtr. staff (J. Gtr.) has a treble clef and contains the lyrics 'WORDS COULD E VERY SAY AND' with musical notation. The E. Bass staff (E. Bass) has a bass clef and contains the lyrics. The second E. Bass staff (E. Bass) has a bass clef and a melodic line. The FM staff (FM) has a grand staff (treble and bass clefs) and contains a complex chordal structure. The FX 5 staff (FX 5) has a treble clef and contains a melodic line. The Vla. staff (Vla.) has a bass clef and contains a melodic line.

57

Perc.

Vib.

J. Gtr.

OHH MY DEAR 'LL BE RIGHT THERE: UN

E. Bass

E. Bass

FM

FX 5

Vla.

Detailed description: This is a page of a musical score for a jazz ensemble. It features seven staves. The top staff is for Percussion (Perc.), showing a rhythmic pattern of eighth notes with accents. The second staff is for Vibraphone (Vib.), with a melodic line in G major. The third staff is for J. Gtr. (Jazz Guitar), which includes the lyrics 'OHH MY DEAR 'LL BE RIGHT THERE: UN' and a melodic line. The fourth staff is for E. Bass (Electric Bass), with a simple bass line. The fifth staff is for E. Bass, with a more active bass line. The sixth staff is for FM (French Mellophone), with a sustained chord. The seventh staff is for FX 5 (FX 5), with a melodic line. The eighth staff is for Vla. (Viola), with a sustained chord. The score is in 4/4 time and G major.

58

Perc. Vib. J. Gtr. E. Bass E. Bass FM FX 5 Vla.

TIL MY DY IND DAY

Detailed description: This is a page of a musical score for a jazz ensemble. It features six staves. The top staff is for Percussion (Perc.), showing a rhythmic pattern of eighth notes with accents. The second staff is for Vibraphone (Vib.), with a melodic line in the right hand and a bass line in the left hand. The third staff is for J. Guitar (J. Gtr.), featuring a vocal line with the lyrics 'TIL MY DY IND DAY' and a guitar accompaniment. The fourth staff is for Electric Bass (E. Bass), providing a bass line. The fifth staff is for Fiddle (FM), with a melodic line. The sixth staff is for Viola (Vla.), with a melodic line. The score is in a key signature of two flats and a 4/4 time signature.

59

Perc.

Vib.

J. Gtr.

E. Bass

E. Bass

FM

FX 5

Vla.

I DON KNOW JUST HOW TO SAY

Detailed description: This is a page of a musical score for a jazz ensemble. It features seven staves. The top staff is for Percussion (Perc.), showing a rhythmic pattern of eighth notes with accents. The second staff is for Vibraphone (Vib.), with a melodic line of eighth notes. The third staff is for J. Guitar (J. Gtr.), which includes the vocal line with lyrics: "I DON KNOW JUST HOW TO SAY". The fourth staff is for Electric Bass (E. Bass), showing a simple bass line. The fifth staff is another Electric Bass (E. Bass) part with a more active line. The sixth staff is for Fretless Mandolin (FM), with a sustained chord. The seventh staff is for FX 5, and the eighth staff is for Viola (Vla.), both with minimal notation.

60

Perc.

Vib.

J. Gtr.

E. Bass

E. Bass

FM

FX 5

Vla.

ALL THE THINGS I FEEL I

Detailed description: This is a page of a musical score for a jazz ensemble. It features seven staves. The Percussion staff (Perc.) has a drum set icon and a rhythmic pattern of eighth notes with 'x' marks above them. The Vibraphone (Vib.) staff has a treble clef and a melodic line with slurs and accents. The J. Gtr. (Jazz Guitar) staff has a treble clef and contains the lyrics 'ALL THE THINGS I FEEL I' with musical notation. The E. Bass (Electric Bass) staff has a bass clef and a melodic line. The FM (Fingered Mallets) staff has a grand staff with a treble clef and a melodic line. The FX 5 (Fingered Xylophone) staff has a treble clef and a melodic line. The Vla. (Vibraphone) staff has a bass clef and a melodic line. The score is in a key signature of two flats and a 4/4 time signature.

61

Perc.

Vib.

J. Gtr.

E. Bass

E. Bass

FM

FX 5

Vla.

JUST KNOW THAT I LOVE YOU SO AND IT GIVES

Detailed description: This is a page of a musical score, page 58, starting at measure 61. The score is arranged in a grand staff with seven staves. From top to bottom: 1. Percussion (Perc.) staff with a snare drum and cymbal pattern. 2. Vibraphone (Vib.) staff with a melodic line. 3. J. Guitar (J. Gtr.) staff with a melodic line and lyrics: "JUST KNOW THAT I LOVE YOU SO AND IT GIVES". 4. Electric Bass (E. Bass) staff with a bass line. 5. Electric Bass (E. Bass) staff with a bass line. 6. FM (Fingered Mandolin) staff with a chordal accompaniment. 7. FX 5 (Effects) staff with a melodic line. 8. Viola (Vla.) staff with a long, sustained note. The key signature has two flats (B-flat and E-flat), and the time signature is 4/4.

62

Fl.

Perc.

Vib.

J. Gtr.

E. Bass

E. Bass

FM

FX 5

Vla.

ME SUCH A THRILL

63

Fl.

Perc.

Vib.

J. Gtr.

E. Bass

E. Bass

FM

FX 5

Vla.

'WE FOUND WHAT THE WORLD

64

Perc. Vib. J. Gtr. E. Bass E. Bass FM FX 5 Vla.

IS SEAR CHIN FOR

Detailed description: This is a page of a musical score, page 61, starting at measure 64. The score is arranged in a grand staff with seven staves. The instruments are Percussion (Perc.), Vibraphone (Vib.), J. Guitar (J. Gtr.), E. Bass (E. Bass), FM (likely French Horn), FX 5 (likely Flute), and Viola (Vla.). The key signature has two flats (B-flat and E-flat), and the time signature is 4/4. The J. Gtr. staff contains the lyrics 'IS SEAR CHIN FOR' under the notes. The Perc. staff shows a rhythmic pattern with eighth notes and rests. The Vib. staff has a melodic line with eighth notes and rests. The E. Bass staff has a bass line with eighth notes and rests. The FM staff has a sustained chord. The FX 5 staff has a melodic line with eighth notes and rests. The Vla. staff has a sustained chord.

65

Perc. Vib. J. Gtr. E. Bass E. Bass FM FX 5 Vla.

HERE RIGHT HERE MY DEAR

Detailed description: This is a page of a musical score, page 62, starting at measure 65. The score is arranged in a vertical stack of staves. From top to bottom, the staves are: Percussion (Perc.), Vibraphone (Vib.), J. Guitar (J. Gtr.), Electric Bass (E. Bass), another Electric Bass (E. Bass), FM (likely a French Horn), FX 5 (likely a Flute), and Viola (Vla.). The J. Gtr. staff contains the lyrics: "HERE", "RIGHT HERE", "MY", and "DEAR". The music is written in a key signature of two flats (B-flat and E-flat) and a 4/4 time signature. The Perc. staff shows a rhythmic pattern with accents. The Vib. staff has a melodic line with a long note at the start. The J. Gtr. staff has a melodic line with lyrics. The E. Bass staves have a bass line. The FM staff has a sustained chord. The FX 5 staff has a few notes. The Vla. staff has a sustained chord.

66

Perc.

Vib.

J. Gtr.

I DON'T HAVE TO LOOK NO MORE

E. Bass

E. Bass

FM

FX 5

Vla.

Detailed description: This is a page of a musical score for a jazz ensemble. The page is numbered 66 at the top left and 63 at the top right. The score is arranged in a vertical stack of staves. From top to bottom, the staves are: Percussion (Perc.), Vibraphone (Vib.), J. Gtr. (Jazz Guitar), E. Bass (Electric Bass), FM (French Mellophone), FX 5 (FX 5), and Vla. (Viola). The J. Gtr. staff contains the lyrics 'I DON'T HAVE TO LOOK NO MORE'. The music is written in a key signature of two flats (B-flat and E-flat) and a 4/4 time signature. The Perc. staff shows a rhythmic pattern with eighth notes and rests. The Vib. staff has a melodic line with eighth notes and rests. The J. Gtr. staff has a melodic line with eighth notes and rests. The E. Bass staff has a bass line with eighth notes and rests. The FM staff has a chordal accompaniment. The FX 5 staff has a melodic line with eighth notes and rests. The Vla. staff has a melodic line with eighth notes and rests.

67

Perc. Vib. J. Gtr. E. Bass E. Bass FM FX 5 Vla.

AND ALL MY DAYS

Detailed description: This is a musical score for a multi-instrument ensemble. The score is written in a key signature of two flats (B-flat and E-flat) and a 4/4 time signature. The instruments are Percussion (Perc.), Vibraphone (Vib.), J. Guitar (J. Gtr.), Electric Bass (E. Bass), FM (likely a Fender MIM Telecaster), FX 5 (likely a Fender Telecaster), and Viola (Vla.). The Percussion part features a steady eighth-note pattern with accents. The Vibraphone part has a melodic line with grace notes. The J. Guitar part includes the lyrics "AND ALL MY DAYS" and features a melodic line with grace notes. The Electric Bass part has a steady eighth-note pattern. The FM part has a sustained chord. The FX 5 part has a melodic line with grace notes. The Viola part has a sustained chord.

68

Perc.

Vib.

J. Gtr.

E. Bass

E. Bass

FM

FX 5

Vla.

ID HOPED AND ID PRAYED:

Detailed description: This is a page of a musical score for a jazz ensemble. It features seven staves. The Percussion staff (Perc.) has a drum set icon and rhythmic notation with 'x' marks. The Vibraphone (Vib.) staff is in treble clef with a key signature of two flats and contains melodic lines. The J. Guitar (J. Gtr.) staff is in treble clef with the same key signature and contains melodic lines with lyrics 'ID HOPED AND ID PRAYED:' underneath. The first Electric Bass (E. Bass) staff is in bass clef and contains a few notes. The second Electric Bass (E. Bass) staff is in bass clef and contains a walking bass line. The FM (French Mellophone) staff is in treble clef with a key signature of two flats and contains a sustained chord. The FX 5 (FX 5) staff is in treble clef with a key signature of two flats and contains a few notes. The Viola (Vla.) staff is in alto clef with a key signature of two flats and contains a long, sustained note.

69

Perc.

Vib.

J. Gtr.

E. Bass

FM

FX 5

Vla.

FOR SOME ONE JUST LIKE YOU

70

Perc.

Vib.

J. Gtr.
MAKE ME FEEL THE WAY YOU DO

E. Bass

E. Bass

FM

FX 5

Vla.

Detailed description: This is a page of a musical score for a jazz ensemble. It features seven staves. The top staff is for Percussion (Perc.) with a snare drum and cymbal. The second staff is for Vibraphone (Vib.) in treble clef. The third staff is for J. Gtr. (Jazz Guitar) in treble clef, with lyrics 'MAKE ME FEEL THE WAY YOU DO' written below the notes. The fourth staff is for E. Bass (Electric Bass) in bass clef. The fifth staff is for FM (French Mellophone) in bass clef. The sixth staff is for FX 5 (Fifth String) in treble clef. The seventh staff is for Vla. (Viola) in bass clef. The music is in a key with two flats (B-flat and E-flat) and a 4/4 time signature. The page number '70' is at the top left, and '67' is at the top right.

71

Perc.

Vib.

J. Gtr.

E. Bass

E. Bass

A.

FM

Vla.

NE VER E VER GON NA GIVE YOU UP

72

Perc.

Vib.

J. Gtr.

E. Bass

E. Bass

A.

FM

Vla.

IM NE VER E VER GON NA STOP

Detailed description: This is a page of a musical score for a jazz ensemble. The page is numbered 72 at the top left and 69 at the top right. The score consists of seven staves. The first staff is for Percussion (Perc.), showing a rhythmic pattern of eighth notes with accents. The second staff is for Vibraphone (Vib.), featuring a melodic line with eighth notes and rests. The third staff is for J. Gtr. (Jazz Guitar), which includes the lyrics 'IM NE VER E VER GON NA STOP' written below the notes. The fourth and fifth staves are for Electric Bass (E. Bass), with the fifth staff providing a more active bass line. The sixth staff is for Alto Saxophone (A.), showing a melodic line. The seventh staff is for French Horn (FM), with a melodic line. The eighth staff is for Viola (Vla.), with a melodic line. The music is in a key with two flats and a 4/4 time signature.

73

Perc.

Vib.

J. Gr.

E. Bass

E. Bass

FM

Vla.

NOW THE WAY I FEEL A BOUT YOU

Detailed description: This is a page of a musical score for a jazz ensemble. It features five staves: Percussion (Perc.), Vibraphone (Vib.), Jazz Guitar (J. Gr.), Electric Bass (E. Bass), and French Horn/Viola (FM/Vla.). The score is in 4/4 time and the key signature has two flats (B-flat and E-flat). The percussion part consists of a steady eighth-note pattern with accents. The vibraphone plays a melodic line with eighth notes. The jazz guitar part includes chords and a melodic line, with lyrics 'NOW THE WAY I FEEL A BOUT YOU' written below it. The electric bass part provides a rhythmic accompaniment with eighth notes. The French horn/viola part features sustained chords and melodic fragments. The page number '73' is written at the top left of the score.

74

Perc.

Vib.

J. Gr.

GIRL I JUST CAN LIVE WITH OUT YOU

E. Bass

E. Bass

FM

Vla.

75

Perc.

Vib.

J. Gtr.

E. Bass

E. Bass

A.

FM

Vla.

IM NE VER E VER GON NA QUIT CAUSE

Detailed description: This is a page of a musical score, page 72, starting at measure 75. The score is arranged in a grand staff format with seven staves. From top to bottom, the staves are: Percussion (Perc.), Vibraphone (Vib.), J. Gtr. (J. Gtr.), E. Bass (E. Bass), E. Bass (E. Bass), A. (A.), FM (FM), and Vla. (Vla.). The J. Gtr. staff contains the lyrics: "IM NE VER E VER GON NA QUIT CAUSE". The music is in a key signature of two flats (B-flat and E-flat) and a 4/4 time signature. The Percussion part features a complex rhythmic pattern with various note values and rests. The Vibraphone part has a melodic line with some grace notes. The J. Gtr. part consists of chords and single notes, with the lyrics written below. The E. Bass part has a bass line with some grace notes. The A. part has a melodic line. The FM part has a complex texture with many notes and some grace notes. The Vla. part has a melodic line with some grace notes.

76

Perc.

Vib.

J. Gtr.

E. Bass

E. Bass

A.

FM

Vla.

QUIT TIN JUST AIN MY STICK.

Detailed description: This is a page of a musical score for a jazz ensemble. It features seven staves. The Percussion staff (Perc.) has a rhythmic pattern of eighth notes with accents. The Vibraphone (Vib.) and J. Gtr. (J. Gtr.) parts are in the key of B-flat major. The J. Gtr. part includes the lyrics 'QUIT TIN JUST AIN MY STICK.' and features a melodic line with some double stops. The E. Bass (Electric Bass) part has a simple bass line. The A. (Alto Saxophone) part has a melodic line. The FM (French Mellophone) part has a melodic line with some slurs. The Vla. (Viola) part has a melodic line with some slurs. The score is in 4/4 time and includes various musical notations such as accents, slurs, and dynamic markings.

77

Perc.

Vib.

J. Gtr.

IMGON NA STAY RIGHT HERE WITH YOU AND

E. Bass

E. Bass

FM

Vla.

Detailed description of the musical score for page 74, measures 77-80:

- Percussion:** Features a rhythmic pattern of eighth notes with accents and rests, marked with 'x' symbols.
- Vibraphone:** Plays a melodic line with eighth notes and rests.
- Jazz Guitar:** Accompanies the vocal line with chords and single notes. The lyrics "IMGON NA STAY RIGHT HERE WITH YOU AND" are written below the staff.
- Electric Bass (top):** Provides a bass line with eighth notes and rests.
- Electric Bass (bottom):** Provides a bass line with eighth notes and rests.
- Fiddle:** Plays a melodic line with eighth notes and rests.
- Viola:** Plays a melodic line with eighth notes and rests.

78

Alto Sax.

Perc.

Vib.

J. Gtr.

E. Bass

E. Bass

FM

Vla.

DO THE THINGS YOU WANT ME YEAH

79

Alto Sax.

Perc.

J. Gtr.

E. Bass

E. Bass

FM

Vla.

Solo

81

Alto Sax.

Perc.

J. Gtr.

E. Bass

E. Bass

FM

Vla.

The musical score for page 81 is arranged in a system with six staves. The top staff is for Alto Saxophone, starting with a treble clef and a key signature of two flats. The second staff is for Percussion, using a snare drum clef and featuring a complex rhythmic pattern with accents and cross-sticks. The third staff is for Jazz Guitar, with a treble clef and a key signature of two flats, showing a melodic line with many slurs. The fourth staff is for Electric Bass, with a bass clef and a key signature of two flats, featuring a melodic line with many slurs. The fifth staff is for Electric Bass, with a bass clef and a key signature of two flats, featuring a melodic line with many slurs. The sixth staff is for Fretless Mandolin, with a treble clef and a key signature of two flats, featuring a melodic line with many slurs. The seventh staff is for Viola, with a bass clef and a key signature of two flats, featuring a melodic line with many slurs.

83

Alto Sax.

Perc.

J. Gtr.

E. Bass

E. Bass

FM

Vla.

The musical score for page 78, starting at measure 83, is arranged in a multi-staff format. The instruments and their parts are as follows:

- Alto Sax.**: A melodic line in the treble clef, starting with a half note, followed by a series of eighth notes, and ending with a long slur over the final two measures.
- Perc.**: A complex rhythmic pattern in the percussion clef, featuring many accents and a mix of eighth and sixteenth notes.
- J. Gtr.**: A rhythmic accompaniment in the treble clef, consisting of eighth notes and slurs.
- E. Bass** (top): A rhythmic accompaniment in the bass clef, consisting of eighth notes and slurs.
- E. Bass** (bottom): A rhythmic accompaniment in the bass clef, consisting of eighth notes and slurs.
- FM**: A melodic line in the treble clef, starting with a half note, followed by a series of eighth notes, and ending with a long slur over the final two measures.
- Vla.**: A few notes in the bass clef, starting with a half note, followed by a long slur over the final two measures.

85

Alto Sax.

Perc.

Vib.

J. Gtr.

E. Bass

E. Bass

A.

FM

FX 5

Vla.

KEEP ON DOIN

The musical score for page 85 is arranged in a multi-staff format. At the top left, the number '85' is written. The instruments and their parts are as follows: Alto Saxophone (Alto Sax.) in the first staff, Percussion (Perc.) in the second staff, Vibraphone (Vib.) in the third staff, Jazz Guitar (J. Gtr.) in the fourth staff, Electric Bass (E. Bass) in the fifth and sixth staves, Trumpet (A.) in the seventh staff, Fiddle (FM) in the eighth staff, Electric Bass (FX 5) in the ninth staff, and Viola (Vla.) in the tenth staff. The key signature is B-flat major (two flats). The time signature is 4/4. The score contains various musical notations including eighth notes, quarter notes, and rests. The text 'KEEP ON DOIN' is written across the J. Gtr. and E. Bass staves. The page number '79' is located in the top right corner.

00:03:57:00
87.1,00
Coda

87

Perc.

Vib.

J. Gtr.

E. Bass

E. Bass

A.

FM

FX 5

Vla.

RIGHT ON DOIN

88

Perc.

Vib.

J. Gtr.

E. Bass

E. Bass

A.

FM

FX 5

Vla.

RIGHT ON

Detailed description: This is a page of a musical score for a jazz ensemble. The page is numbered 81 in the top right corner and 88 in the top left corner. The score consists of ten staves. From top to bottom, they are: Percussion (Perc.), Vibraphone (Vib.), J. Guitar (J. Gtr.), Electric Bass (E. Bass), another Electric Bass (E. Bass), Alto Saxophone (A.), Fiddle (FM), FX 5, and Viola (Vla.). The Percussion staff shows a rhythmic pattern with eighth notes and rests. The Vibraphone staff has a few notes in the latter half of the measure. The J. Guitar staff has a 'RIGHT ON' annotation above it. The E. Bass staves show a walking bass line. The A. staff has a few notes. The FM staff has a long note with a fermata. The FX 5 staff has a few notes. The Vla. staff has a few notes.

89

Perc.

Vib.

J. Gtr.

E. Bass

E. Bass

A.

FM

FX 5

Vla.

RIGHT ON RIGHT ON DO IN

Detailed description: This is a page of a musical score for a jazz ensemble. It features eight staves. The Percussion staff (Perc.) has a drum set icon and a rhythmic pattern of eighth notes with 'x' marks. The Vibraphone (Vib.) staff has a treble clef and a melodic line. The J. Guitar (J. Gtr.) staff has a treble clef and includes the lyrics 'RIGHT ON RIGHT ON DO IN' with a guitar fretboard diagram for the 'DO IN' part. The two Electric Bass (E. Bass) staves have bass clefs and provide harmonic support. The Alto Saxophone (A.) staff has a treble clef. The French Mellophone (FM) staff has a treble clef and contains sustained chords. The FX 5 staff has a treble clef. The Viola (Vla.) staff has a bass clef and a long, sustained note. The key signature has two flats, and the time signature is 4/4.

90

Fl.

Perc.

Vib.

J. Gtr.

E. Bass

E. Bass

A.

FM

FX 5

Vla.

KEEP ON DOIN

91

Fl.

Perc.

J. Gtr.

E. Bass

E. Bass

FM

FX 5

Vla.

Detailed description: This page of a musical score covers measures 91 through 94. The score is arranged in a grand staff format with seven staves. The top staff is for Flute (Fl.), the second for Percussion (Perc.), the third for J. Gtr., the fourth for E. Bass, the fifth for E. Bass, the sixth for FM (likely a double bass or piano), and the seventh for FX 5 (likely a saxophone). The eighth staff is for Vla. (Viola). The music is in a key signature of two flats (B-flat and E-flat) and a common time signature. Measure 91 shows the Flute playing a quarter note G4, followed by rests. The Percussion part features a complex rhythmic pattern with eighth and sixteenth notes. The J. Gtr. part has a melodic line with a sharp sign above the second measure. The E. Bass part has a bass line with a sharp sign above the second measure. The FM part has a sustained chord. The FX 5 part has a melodic line with a sharp sign above the second measure. The Vla. part has a melodic line with a sharp sign above the second measure.

92

Perc. Vib. J. Gtr. E. Bass E. Bass A. FM FX 5 Vla.

KEEP ON RIGHT ON DO

Detailed description: This is a page of a musical score for a jazz ensemble. The page is numbered 92 at the top left and 85 at the top right. The score is arranged in a vertical stack of staves. From top to bottom, the staves are: Percussion (Perc.), Vibraphone (Vib.), J. Guitar (J. Gtr.), Electric Bass (E. Bass), another Electric Bass (E. Bass), Alto Saxophone (A.), Fiddle (FM), FX 5, and Viola (Vla.). The J. Gtr. staff contains the lyrics 'KEEP ON RIGHT ON DO' aligned with the notes. The music is written in a key signature of two flats (B-flat and E-flat) and a 4/4 time signature. The Perc. part features a rhythmic pattern of eighth notes with accents. The Vib. part has a melodic line with grace notes. The J. Gtr. part has a sparse accompaniment. The E. Bass parts provide a steady bass line. The A. part has a melodic line. The FM part has a sustained chord. The FX 5 part has a few notes. The Vla. part has a few notes.

93

Perc. Vib. J. Gtr. E. Bass E. Bass A. FM FX 5 Vla.

IN

Detailed description: This is a page of a musical score, page 86, starting at measure 93. The score is arranged in a vertical stack of staves. From top to bottom, the staves are: Percussion (Perc.), Vibraphone (Vib.), J. Guitar (J. Gtr.), Electric Bass (E. Bass), another Electric Bass (E. Bass), A., FM (likely French Mallet Horn), FX 5 (likely a mallet instrument), and Viola (Vla.). The Percussion staff shows a rhythmic pattern of eighth notes with 'x' marks above them. The Vibraphone staff has a few notes in the first measure. The J. Guitar staff has a measure rest followed by notes, with the word 'IN' written below the first measure. The E. Bass staff has notes starting in the second measure. The second E. Bass staff has a rhythmic pattern of eighth notes. The A. staff has a few notes in the first measure. The FM staff has a sustained chord. The FX 5 staff has a few notes in the first measure. The Viola staff has a long, sustained note starting in the first measure.

94

Fl.

Perc.

J. Gtr.

E. Bass

E. Bass

FM

FX 5

Vla.

Detailed description: This page of a musical score covers measures 94 to 97. The score is for a multi-instrument ensemble. The Flute (Fl.) part begins with a rest in measure 94, followed by eighth-note triplets in measures 95 and 96, and a quarter note in measure 97. The Percussion (Perc.) part features a complex rhythmic pattern with various note values and rests. The J. Gtr. (Jazz Guitar) part has a melodic line with eighth notes and rests. The E. Bass (Electric Bass) part has a rhythmic line with eighth notes and rests. The FM (Fingered Mandolin) part has a melodic line with eighth notes and rests. The FX 5 (Fiddle) part has a melodic line with eighth notes and rests. The Vla. (Viola) part has a melodic line with eighth notes and rests. The score is in a key signature of two flats and a common time signature.

96

Perc.

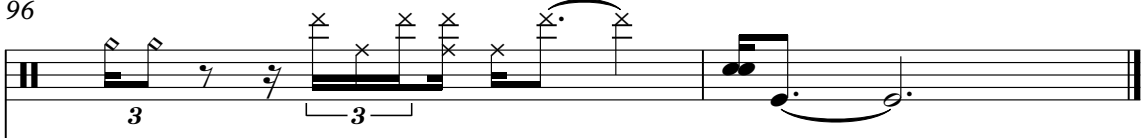

J. Gtr.

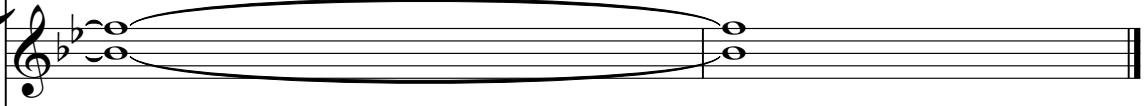

E. Bass

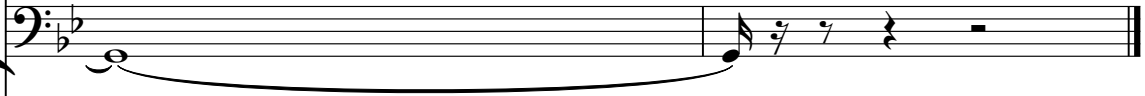

FM

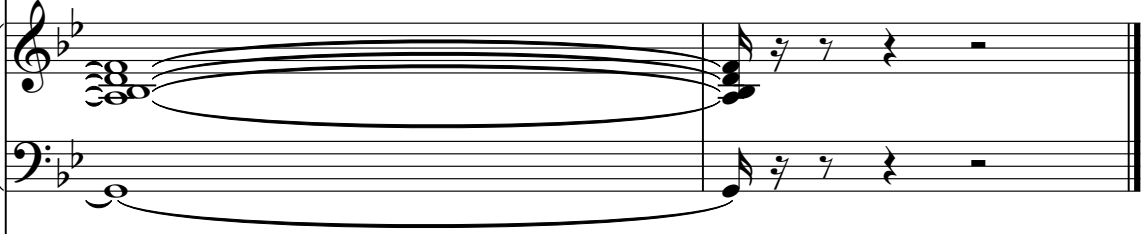

Vla.

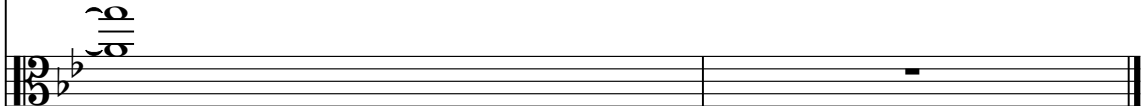

Detailed description: This page of a musical score, numbered 88, contains measures 96 through 98. It features five staves: Percussion (Perc.), Jazz Guitar (J. Gtr.), Electric Bass (E. Bass), Fingered Piano (FM), and Viola (Vla.). The Percussion staff shows a complex rhythmic pattern with triplets and accents. The J. Gtr., E. Bass, and FM staves all feature a long, sustained chord that spans across measures 96 and 97. The Viola staff also has a long sustained chord. The music is in a key with two flats (B-flat and E-flat) and a 3/4 time signature.

Flute Barry White - Never

♩ = 87,000023

9 2

14 6

23 6

32 18 2

54 6

63 26

91 2

97

(C) 1998 by M-LIVE s.r.l.;Ed. Warner Chappell Music Italiana
(C) 1998 by M-LIVE s.r.l.;Ed. Warner Chappell Music Italiana

Alto Saxophone Barry White - Never

♩ = 87,000023

77

82

85

10

97

(C) 1998 by M-LIVE s.r.l.;Ed. Warner Chappell Music Italiana
(C) 1998 by M-LIVE s.r.l.;Ed. Warner Chappell Music Italiana

Percussion Barry White - Never

♩ = 87,000023
2

5

7

9

11

13

15

17

19

21

(C) 1998 by M-LIVE s.r.l.;Ed. Warner Chappell Music Italiana
(C) 1998 by M-LIVE s.r.l.;Ed. Warner Chappell Music Italiana

V.S.

Percussion

23

Musical notation for measures 23-24. The top staff shows a sequence of eighth notes with stems pointing down, alternating with rests. The bottom staff shows a complex rhythmic pattern with eighth notes and rests, including some notes with 'x' marks.

25

Musical notation for measures 25-26. Similar to the previous system, it features a top staff with eighth notes and rests, and a bottom staff with a complex rhythmic pattern.

27

Musical notation for measures 27-28. Continues the rhythmic pattern with eighth notes and rests in the top staff, and a complex bottom staff.

29

Musical notation for measures 29-30. Continues the rhythmic pattern with eighth notes and rests in the top staff, and a complex bottom staff.

31

Musical notation for measures 31-32. Continues the rhythmic pattern with eighth notes and rests in the top staff, and a complex bottom staff.

33

Musical notation for measures 33-34. Continues the rhythmic pattern with eighth notes and rests in the top staff, and a complex bottom staff.

35

Musical notation for measures 35-36. Continues the rhythmic pattern with eighth notes and rests in the top staff, and a complex bottom staff.

37

Musical notation for measures 37-38. Continues the rhythmic pattern with eighth notes and rests in the top staff, and a complex bottom staff.

39

Musical notation for measures 39-40. Continues the rhythmic pattern with eighth notes and rests in the top staff, and a complex bottom staff.

41

Musical notation for measures 41-42. Continues the rhythmic pattern with eighth notes and rests in the top staff, and a complex bottom staff.

Percussion

43

Musical notation for measure 43, featuring a treble clef, a key signature of one sharp (F#), and a 2/4 time signature. The notation includes a series of eighth notes with stems pointing up and down, and a series of eighth notes with stems pointing up and down, indicating a rhythmic pattern.

45

Musical notation for measure 45, featuring a treble clef, a key signature of one sharp (F#), and a 2/4 time signature. The notation includes a series of eighth notes with stems pointing up and down, and a series of eighth notes with stems pointing up and down, indicating a rhythmic pattern.

47

Musical notation for measure 47, featuring a treble clef, a key signature of one sharp (F#), and a 2/4 time signature. The notation includes a series of eighth notes with stems pointing up and down, and a series of eighth notes with stems pointing up and down, indicating a rhythmic pattern.

49

Musical notation for measure 49, featuring a treble clef, a key signature of one sharp (F#), and a 2/4 time signature. The notation includes a series of eighth notes with stems pointing up and down, and a series of eighth notes with stems pointing up and down, indicating a rhythmic pattern.

51

Musical notation for measure 51, featuring a treble clef, a key signature of one sharp (F#), and a 2/4 time signature. The notation includes a series of eighth notes with stems pointing up and down, and a series of eighth notes with stems pointing up and down, indicating a rhythmic pattern.

53

Musical notation for measure 53, featuring a treble clef, a key signature of one sharp (F#), and a 2/4 time signature. The notation includes a series of eighth notes with stems pointing up and down, and a series of eighth notes with stems pointing up and down, indicating a rhythmic pattern.

55

Musical notation for measure 55, featuring a treble clef, a key signature of one sharp (F#), and a 2/4 time signature. The notation includes a series of eighth notes with stems pointing up and down, and a series of eighth notes with stems pointing up and down, indicating a rhythmic pattern.

57

Musical notation for measure 57, featuring a treble clef, a key signature of one sharp (F#), and a 2/4 time signature. The notation includes a series of eighth notes with stems pointing up and down, and a series of eighth notes with stems pointing up and down, indicating a rhythmic pattern.

59

Musical notation for measure 59, featuring a treble clef, a key signature of one sharp (F#), and a 2/4 time signature. The notation includes a series of eighth notes with stems pointing up and down, and a series of eighth notes with stems pointing up and down, indicating a rhythmic pattern.

61

Musical notation for measure 61, featuring a treble clef, a key signature of one sharp (F#), and a 2/4 time signature. The notation includes a series of eighth notes with stems pointing up and down, and a series of eighth notes with stems pointing up and down, indicating a rhythmic pattern.

V.S.

Percussion

This musical score for Percussion consists of ten systems, each with a measure number on the left and a staff with two lines. The notation includes various rhythmic symbols such as eighth notes, quarter notes, and rests, along with 'x' marks indicating specific percussive sounds. Some systems also feature upward-pointing triangles. The notation is arranged in a standard musical format with a double bar line at the end of each system.

63

65

67

69

71

73

75

77

79

81

83

Musical notation for measure 83, featuring a drum set (snare, tom, cymbal) and a bass line. The drum part consists of a repeating eighth-note pattern with snare on the first and third beats, and tom on the second and fourth beats. The bass line consists of a steady eighth-note pattern.

85

Musical notation for measure 85, featuring a drum set and a bass line. The drum part continues with the repeating eighth-note pattern. The bass line features a more complex rhythmic pattern with eighth and sixteenth notes.

87

Musical notation for measure 87, featuring a drum set and a bass line. The drum part continues with the repeating eighth-note pattern. The bass line features a more complex rhythmic pattern with eighth and sixteenth notes.

89

Musical notation for measure 89, featuring a drum set and a bass line. The drum part continues with the repeating eighth-note pattern. The bass line features a more complex rhythmic pattern with eighth and sixteenth notes.

91

Musical notation for measure 91, featuring a drum set and a bass line. The drum part continues with the repeating eighth-note pattern. The bass line features a more complex rhythmic pattern with eighth and sixteenth notes.

93

Musical notation for measure 93, featuring a drum set and a bass line. The drum part continues with the repeating eighth-note pattern. The bass line features a more complex rhythmic pattern with eighth and sixteenth notes.

95

Musical notation for measure 95, featuring a drum set and a bass line. The drum part continues with the repeating eighth-note pattern. The bass line features a more complex rhythmic pattern with eighth and sixteenth notes, including a triplet of eighth notes.

97

Musical notation for measure 97, featuring a drum set and a bass line. The drum part continues with the repeating eighth-note pattern. The bass line features a more complex rhythmic pattern with eighth and sixteenth notes, including a triplet of eighth notes.

Vibraphone Barry White - Never

♩ = 87,000023

2

5

8

11

14

18

20

(C) 1998 by M-LIVE s.r.l.;Ed. Warner Chappell Music Italiana
(C) 1998 by M-LIVE s.r.l.;Ed. Warner Chappell Music Italiana

23



26



29



32



35



38



41



44



47



51



55

57

60

63

66

69

72

75

77

7

4

Vibraphone

86



90



97



Barry White - Never

♩ = 87,000023

~~NEVER~~ ~~WANT~~ ~~KNOW~~ ~~NEED~~ ~~TOO~~ ~~CAUSE~~

'VE FOUND WHAT WORLD IS SEARCHING FOR

~~NEVER~~ ~~WANT~~ ~~KNOW~~ ~~NEED~~ ~~TOO~~ ~~CAUSE~~ GIRL I

DO FOR ~~NEVER~~ ~~NEED~~ ~~TOO~~ ~~CAUSE~~ ~~NEED~~ ~~TOO~~ ~~CAUSE~~

'LL SEARCH THROUGH

HAVE TO KEEP PLEASED IN ~~WANT~~ ~~WANT~~ ~~WANT~~ GIVE YOU ALL OF ME AS

MUCH ~~WANT~~ ~~WANT~~ ~~WANT~~ MOVE TO YOUR KNOW WHAT ALL WANT TO

KNOW YOU NEED IT GIRL AND YOU ~~NEED~~ ~~TOO~~ ~~CAUSE~~ ~~NEED~~ ~~TOO~~ ~~CAUSE~~

'VE FOUND WHAT WORLD IS SEARCHING FOR

HERE ~~NEED~~ ~~TOO~~ ~~CAUSE~~ ~~NEED~~ ~~TOO~~ ~~CAUSE~~ ~~NEED~~ ~~TOO~~ ~~CAUSE~~ ~~NEED~~ ~~TOO~~ ~~CAUSE~~ ~~NEED~~ ~~TOO~~ ~~CAUSE~~

(C) 1998 by M-LIVE s.r.l.; Ed. Warner Chappell Music Italiana
 (C) 1998 by M-LIVE s.r.l.; Ed. Warner Chappell Music Italiana

V.S.

35

AND ALL MY DAYS HOPEND PRAYED FOR SOMENJUSIKYOU

38

MAKE ME FEEL THE WAY YOU DO NERER GONNA GIVE YOU UP

40

MNER EVERON NA STOP NOWFEELA BOUT YOU GIRLJUSTINWOTH YOU

43

MNER EVERON NA QUIT CAUSE QUIN JUSTIN MY STICK

45

GIRLWITH YOU AND ATHENOUSANTME TOWHAT WANT

48

GIRL YOU GOTIT YOUGOTT WHAT

51

WOTED DON WAN NA SEE YOU WOTH IT

54

YOUVENMMUCHORE THANWOTERAY AND

57

ONREARL BRIGHHERE UN TIMDAY DONOW JUST HOW TO SAY

60

ATHHIGSL I JUSTONWAILOVEOUSOAND GIVES MECHHILL

63



'VE FOUND WHAT WORLD IS SEARCHIN

65



HERE RIGHHERE MY DEAR I DONTVEO LOOK NOMORE

67



AND ALL MY DAYS HOPEND PRAYED FOR SOMENJUSTKOU

70



MAKE ME FEELTHE WAY YOU DO NEVER GONNA GIVE YOU UP

72



'MNER EVERON NA STOP NOWFEELA BOUT YOU GIRJUSTINWICH YOU

75



'MNER EVERON NA QUIT CAUSE QUIN JUSTIN MY STICK

77



GONSARAGHERWITH YOU AND ACHENOSANIMEYICAH Solo

80



84



KEROIN

87



RIGHN DOIN RIGHT ON RIGHT ONRIGHN DIN V.S.

4

Jazz Guitar

90



KEEP ONDOIN

KEENRIGHT ONDO

93



IN

97

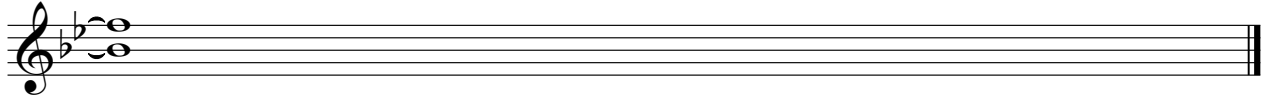

Electric Bass Barry White - Never

♩ = 87,000023
6

6

10

15

19

23

27

31

34

(C) 1998 by M-LIVE s.r.l.;Ed. Warner Chappell Music Italiana
(C) 1998 by M-LIVE s.r.l.;Ed. Warner Chappell Music Italiana

2
38 Electric Bass

41

44

47

51

55

59

63

67

72

Detailed description: This image shows a musical score for an electric bass instrument, spanning measures 38 to 72. The score is written in bass clef with a key signature of one flat (B-flat). The music consists of a series of chords, primarily triads and dyads, often with a dotted rhythm. The notes are frequently beamed together in pairs or groups of three. The score is divided into systems, with measure numbers 38, 41, 44, 47, 51, 55, 59, 63, 67, and 72 marking the beginning of each system. The notation includes stems, beams, and dots above notes to indicate rhythm and articulation.

Electric Bass

75

Musical staff for measure 75, featuring a bass clef, a key signature of one flat (B-flat), and a 4/4 time signature. The staff contains six measures of music, each with a dotted quarter note followed by an eighth note, and a pair of beamed eighth notes. The notes are G2, F2, E2, D2, C2, and B1, respectively.

78

Musical staff for measure 78, featuring a bass clef, a key signature of one flat (B-flat), and a 4/4 time signature. The staff contains six measures of music, each with a dotted quarter note followed by an eighth note, and a pair of beamed eighth notes. The notes are G2, F2, E2, D2, C2, and B1, respectively.

81

Musical staff for measure 81, featuring a bass clef, a key signature of one flat (B-flat), and a 4/4 time signature. The staff contains six measures of music, each with a dotted quarter note followed by an eighth note, and a pair of beamed eighth notes. The notes are G2, F2, E2, D2, C2, and B1, respectively.

84

Musical staff for measure 84, featuring a bass clef, a key signature of one flat (B-flat), and a 4/4 time signature. The staff contains six measures of music, each with a dotted quarter note followed by an eighth note, and a pair of beamed eighth notes. The notes are G2, F2, E2, D2, C2, and B1, respectively.

87

Musical staff for measure 87, featuring a bass clef, a key signature of one flat (B-flat), and a 4/4 time signature. The staff contains four measures of music, each with a dotted quarter note followed by an eighth note, and a pair of beamed eighth notes. The notes are G2, F2, E2, D2, C2, and B1, respectively.

91

Musical staff for measure 91, featuring a bass clef, a key signature of one flat (B-flat), and a 4/4 time signature. The staff contains four measures of music, each with a dotted quarter note followed by an eighth note, and a pair of beamed eighth notes. The notes are G2, F2, E2, D2, C2, and B1, respectively. A double bar line is present at the end of the staff, with the number '2' written above it.

97

Musical staff for measure 97, featuring a bass clef, a key signature of one flat (B-flat), and a 4/4 time signature. The staff contains one measure of music, which is a whole rest.

Barry White - Never

5-string Electric Bass

$\text{♩} = 87,000023$

5

9

12

15

18

21

24

27

30

33

(C) 1998 by M-LIVE s.r.l.;Ed. Warner Chappell Music Italiana
(C) 1998 by M-LIVE s.r.l.;Ed. Warner Chappell Music Italiana

V.S.

66



69



72



75



78



81



84



87



90



93



V.S.

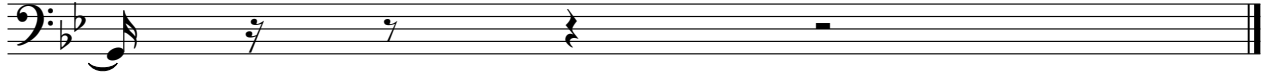

Alto

Barry White - Never

♩ = 87,000023

8 2

13

16

20 17

40 2

45 3

51 17

71 2

76 9

88

(C) 1998 by M-LIVE s.r.l.;Ed. Warner Chappell Music Italiana
(C) 1998 by M-LIVE s.r.l.;Ed. Warner Chappell Music Italiana

2

Alto

92

Musical notation for Alto, measures 92-96. Measure 92 is a whole rest. Measure 93 contains an eighth-note chord (F4, A4, C5) followed by eighth-note pairs (G4, A4), (B4, C5), (D5, E5), and (F5, G5). Measure 94 has a quarter note G4, a quarter note A4, and a quarter note B4. Measure 95 has a quarter rest and a quarter note C5. Measure 96 is a whole rest. Measure 97 is a whole rest. A large number 3 is positioned above the staff in measure 97.

97

Musical notation for Alto, measure 97. The staff contains a whole rest.

FM Synth Barry White - Never

♩ = 87,000023

6

12

17

23

29

(C) 1998 by M-LIVE s.r.l.;Ed. Warner Chappell Music Italiana
(C) 1998 by M-LIVE s.r.l.;Ed. Warner Chappell Music Italiana

V.S.

37

41

45

50

56

62

70

Musical notation for measures 70-73. The system consists of two staves: a treble clef staff and a bass clef staff. The key signature has two flats (B-flat and E-flat). The time signature is 4/4. The music features a complex texture with many beamed notes and rests, creating a dense, rhythmic pattern. The bass line is more melodic, with some notes tied across measures.

74

Musical notation for measures 74-77. The system consists of two staves: a treble clef staff and a bass clef staff. The key signature has two flats (B-flat and E-flat). The time signature is 4/4. The music continues with a complex texture of beamed notes and rests. The bass line remains melodic with some ties.

78

Musical notation for measures 78-81. The system consists of two staves: a treble clef staff and a bass clef staff. The key signature has two flats (B-flat and E-flat). The time signature is 4/4. The music continues with a complex texture of beamed notes and rests. The bass line remains melodic with some ties.

82

Musical notation for measures 82-85. The system consists of two staves: a treble clef staff and a bass clef staff. The key signature has two flats (B-flat and E-flat). The time signature is 4/4. The music continues with a complex texture of beamed notes and rests. The bass line remains melodic with some ties.

86

Musical notation for measures 86-91. The system consists of two staves: a treble clef staff and a bass clef staff. The key signature has two flats (B-flat and E-flat). The time signature is 4/4. The music continues with a complex texture of beamed notes and rests. The bass line remains melodic with some ties.

92

Musical notation for measures 92-95. The system consists of two staves: a treble clef staff and a bass clef staff. The key signature has two flats (B-flat and E-flat). The time signature is 4/4. The music continues with a complex texture of beamed notes and rests. The bass line remains melodic with some ties.

V.S.

97

The musical score consists of two staves, Treble and Bass clef, in a key signature of two flats (B-flat and E-flat). Measure 97 begins with a treble clef and a bass clef. The first measure of the treble staff contains a chord of three notes: G4, B-flat4, and D5. The first measure of the bass staff contains a chord of three notes: G2, B-flat2, and D3. The second and third measures of both staves contain a single eighth note with a slash through it, indicating a rest. The fourth measure of both staves contains a single eighth note with a slash through it, indicating a rest. The piece concludes with a double bar line.

Barry White - Never
FX 5 (Brightness)

♩ = 87,000023

13

17

22

26

31

37

7

48

53

57

62

(C) 1998 by M-LIVE s.r.l.;Ed. Warner Chappell Music Italiana
(C) 1998 by M-LIVE s.r.l.;Ed. Warner Chappell Music Italiana

V.S.

2

FX 5 (Brightness)

67 **15**

86

91 **2**

97

Viola Barry White - Never

♩ = 87,000023

5 6 8 11 25 32 38 41 44 48 55 62

(C) 1998 by M-LIVE s.r.l.;Ed. Warner Chappell Music Italiana
(C) 1998 by M-LIVE s.r.l.;Ed. Warner Chappell Music Italiana

V.S.

2

70

Viola

73

76

80

88

93

97