

Nina Simone - My Baby Just Cares For Me 3

♩ = 118,002220
0210BABY

Bass Flute

Percussion

Kora

Acoustic Bass

Solo

Solo

5

Perc.

Kora

A. Bass

Solo

Solo

7

B. Fl.

Perc.

Kora

A. Bass

Solo

Solo

9

B. Fl.

Perc.

Kora

A. Bass

Solo

Solo

11

B. Fl. Perc. Kora A. Bass Solo Solo

This musical system covers measures 11 and 12. The B. Fl. part features a melodic line with a triplet of eighth notes in measure 11. The Perc. part has a steady eighth-note pattern. The Kora part consists of block chords. The A. Bass part has a simple bass line. The Solo part is split into two staves, with the upper staff playing a melodic line and the lower staff playing a rhythmic accompaniment.

13

B. Fl. Perc. Kora A. Bass Solo Solo

This musical system covers measures 13 and 14. The B. Fl. part has a melodic line with a slur over the final two notes of measure 13. The Perc. part continues with its eighth-note pattern. The Kora part has block chords. The A. Bass part has a simple bass line. The Solo part is split into two staves, with the upper staff playing a melodic line and the lower staff playing a rhythmic accompaniment.

15

B. Fl.

Perc.

Kora

A. Bass

Solo

Solo

17

B. Fl.

Perc.

Kora

A. Bass

Solo

Solo

19

B. Fl.

Perc.

Kora

A. Bass

Solo

Solo

Detailed description: This system contains measures 19 and 20. The B. Fl. part starts with a quarter note G4, followed by a quarter rest, then a quarter note A4, and a quarter note B4. The Perc. part has a steady eighth-note pattern. The Kora part consists of chords: G#4-A#4, G#4-A#4, G#4-A#4, G#4-A#4, G#4-A#4, G#4-A#4, G#4-A#4, G#4-A#4. The A. Bass part has notes: G#2, A#2, G#2, A#2, G#2, A#2, G#2, A#2. The Solo parts have a complex rhythmic pattern with many rests and accidentals.

21

♩ = 116,000313

B. Fl.

Perc.

Kora

A. Bass

Solo

Solo

Detailed description: This system contains measures 21 and 22. The B. Fl. part has a triplet of G#4, A#4, B4, followed by a quarter rest, then a quarter note G#4, a quarter note A#4, and a quarter note B4. The Perc. part has a steady eighth-note pattern with a triplet of eighth notes in measure 22. The Kora part has chords: G#4-A#4, G#4-A#4, G#4-A#4, G#4-A#4, G#4-A#4, G#4-A#4, G#4-A#4, G#4-A#4. The A. Bass part has notes: G#2, A#2, G#2, A#2, G#2, A#2, G#2, A#2. The Solo parts have a complex rhythmic pattern with many rests and accidentals.

6

24 ♩ = 119,000397

B. Fl.

Perc.

♩ = 119,000397

Kora

A. Bass

Solo

Solo

26

B. Fl.

Perc.

Kora

A. Bass

Solo

Solo

28

B. Fl.

Perc.

Kora

A. Bass

Solo

Solo

30

B. Fl.

Perc.

Kora

A. Bass

Solo

Solo

32

B. Fl.

Perc.

Kora

A. Bass

Solo

Solo

Detailed description: This system of music covers measures 32 and 33. The B. Fl. part starts with a whole rest in measure 32, followed by a quarter rest, then a quarter note G4, a quarter note A4, and a quarter note B4 in measure 33, which is tied to the next system. The Perc. part features a steady eighth-note pattern. The Kora part consists of block chords in the right hand. The A. Bass part has a simple bass line with notes G2, A2, B2, C3, D3, E3, and F3. The Solo parts consist of two staves with chords and melodic fragments.

34

B. Fl.

Perc.

Kora

A. Bass

Solo

Solo

Detailed description: This system of music covers measures 34 and 35. The B. Fl. part begins in measure 34 with a half note G4, followed by quarter notes A4, B4, and C5 in measure 35, which is tied to the next system. The Perc. part continues with the eighth-note pattern. The Kora part continues with block chords. The A. Bass part has a bass line with notes G2, A2, B2, C3, D3, E3, and F3, ending with a triplet of notes in measure 35. The Solo parts consist of two staves with chords and melodic fragments.

36

B. Fl.

Perc.

Kora

A. Bass

Solo

Solo

38

B. Fl.

Perc.

Kora

A. Bass

Solo

Solo

40

Perc. 

Kora 

A. Bass 

Solo 

Solo 

42

Perc. 

A. Bass 

Solo 

Solo 

44

Perc. 

A. Bass 

Solo 

Solo 

46

Perc. 

A. Bass 

Solo 

Solo 

48

Perc. 

A. Bass 

Solo 

Solo 

50

Perc. 

A. Bass 

Solo 

Solo 

Perc. 

A. Bass 

Solo 

Solo 

54 ♩ = 120,000000 ♩ = 121,004089 ♩ = 122,001808 ♩ = 123,002235

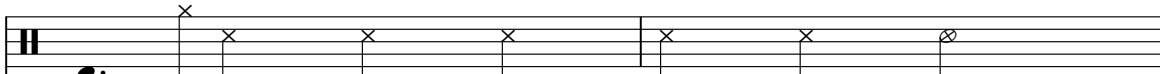
Perc. 

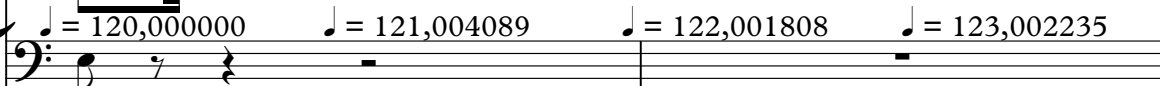
A. Bass 

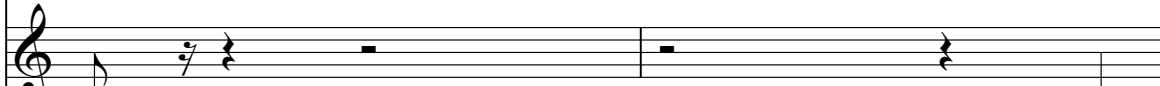
Solo 

Solo 

56 ♩ = 119,000397

Perc. 

Kora 

A. Bass 

Solo 

Solo 

58

Perc. 

Kora 

A. Bass 

Solo 

60 ♩ = 118,002220

Perc. 

Kora 

A. Bass 

Solo 

62

Perc. 

Kora 

A. Bass 

Solo 

64

Musical score for measures 64-65. The score includes five staves: Percussion (Perc.), Kora, Acoustic Bass (A. Bass), and two Solo staves. The Percussion staff shows a consistent rhythmic pattern of eighth notes. The Kora staff features block chords in the right hand and a melodic line in the left hand. The A. Bass staff provides a bass line with some chromatic movement. The Solo staves contain melodic lines for two instruments, with the bottom staff featuring a triplet of eighth notes.

66 ♩ = 119,000397 ♩ = 120,000000 ♩ = 121,004089

Musical score for measures 66-67. The score includes five staves: Percussion (Perc.), Kora, Acoustic Bass (A. Bass), and two Solo staves. The Percussion staff continues with the same rhythmic pattern. The Kora staff has block chords and a melodic line. The A. Bass staff has a bass line with a triplet of eighth notes in measure 67. The Solo staves feature melodic lines with sixteenth-note runs and are marked with '6' and '3' above the notes, indicating sixteenth and triplet rhythms.

68 ♩ = 122,001808

Perc. 

♩ = 122,001808

Kora 

A. Bass 

Solo 

Solo 

70 ♩ = 120,000000 ♩ = 119,000397

Perc. 

♩ = 120,000000 ♩ = 119,000397

Kora 

A. Bass 

Solo 

Solo 

72

B. Fl.

Perc.

Kora

A. Bass

Solo

Solo

74

B. Fl.

Perc.

Kora

A. Bass

Solo

Solo

76

B. Fl.

Perc.

Kora

A. Bass

Solo

Solo

78

B. Fl.

Perc.

Kora

A. Bass

Solo

Solo

80

B. Fl.

Perc.

Kora

A. Bass

Solo

Solo

82

B. Fl.

Perc.

Kora

A. Bass

Solo

Solo

84

B. Fl.

Perc.

Kora

A. Bass

Solo

Solo

86 ♩ = 116,000313 ♩ = 114,002335 ♩ = 119,000397

B. Fl.

Perc.

Kora

A. Bass

Solo

Solo

89

B. Fl.

Perc.

Kora

A. Bass

Solo

Solo

91

B. Fl.

Perc.

Kora

A. Bass

Solo

Solo

93

B. Fl.

Perc.

Kora

A. Bass

Solo

Solo

Detailed description: This system of music covers measures 93 and 94. The B. Fl. part starts with a half note G4, followed by a quarter note A4, and a quarter note B4. The Perc. part features a steady eighth-note pattern. The Kora part consists of a series of chords. The A. Bass part has a simple bass line. The Solo part includes a melodic line and a rhythmic accompaniment.

95

B. Fl.

Perc.

Kora

A. Bass

Solo

Solo

Detailed description: This system of music covers measures 95 and 96. The B. Fl. part continues with a melodic line. The Perc. part maintains its eighth-note pattern. The Kora part continues with chords. The A. Bass part has a simple bass line. The Solo part includes a melodic line and a rhythmic accompaniment.

97

B. Fl.

Perc.

Kora

A. Bass

Solo

99

B. Fl.

Perc.

Kora

A. Bass

Solo

101

B. Fl. Perc. Kora A. Bass Solo Solo

Detailed description: This system contains measures 101 and 102. The B. Fl. part features a melodic line with a triplet in measure 102. The Perc. part has a steady eighth-note pattern. The Kora part consists of block chords. The A. Bass part has a simple bass line. The Solo part includes a complex melodic line with triplets and a dense chordal accompaniment.

103

B. Fl. Perc. Kora A. Bass Solo Solo

Detailed description: This system contains measures 103 and 104. The B. Fl. part continues the melodic line. The Perc. part has a triplet in measure 103. The Kora part continues with block chords. The A. Bass part has a simple bass line. The Solo part includes a complex melodic line with triplets and a dense chordal accompaniment.

105

B. Fl.

Perc.

Kora

A. Bass

Solo

Solo

Detailed description: This block contains the musical notation for measures 105 and 106. It features six staves: B. Fl. (Bass Flute), Perc. (Percussion), Kora (Kora), A. Bass (Acoustic Bass), Solo (Solo guitar), and Solo (Solo guitar). The B. Fl. staff has a treble clef and a key signature of one sharp (F#). The Perc. staff has a double bar line. The Kora staff has a treble clef and a key signature of one sharp. The A. Bass staff has a bass clef and a key signature of one sharp. The two Solo staves have treble clefs and a key signature of one sharp. The music includes various note values, rests, and articulation marks.

107

Perc.

Kora

A. Bass

Solo

Solo

Detailed description: This block contains the musical notation for measures 107 and 108. It features five staves: Perc. (Percussion), Kora (Kora), A. Bass (Acoustic Bass), Solo (Solo guitar), and Solo (Solo guitar). The Perc. staff has a double bar line and includes a triplet of eighth notes and a sextuplet of eighth notes. The Kora staff has a treble clef and a key signature of one sharp, with a long note in measure 108. The A. Bass staff has a bass clef and a key signature of one sharp. The two Solo staves have treble clefs and a key signature of one sharp, with a triplet of eighth notes in measure 108. The music includes various note values, rests, and articulation marks.

108

Perc. 

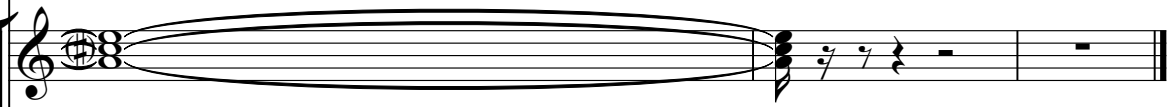
Kora 

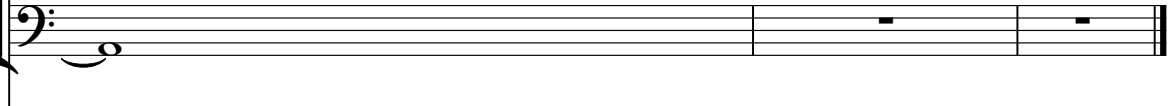
A. Bass 

Solo 

Solo 

Nina Simone - My Baby Just Cares For Me 3

Bass Flute

$\text{♩} = 118,002220$
0210BABY

6 2

11

16

20 $\text{♩} = 116,000313$ $\text{♩} = 119,000397$

25

29

34

38 $\text{♩} = 120,000000$ $\text{♩} = 120,000000$ $\text{♩} = 120,000000$ $\text{♩} = 119,000397$

15 **4**

60 $\text{♩} = 118,002220$ $\text{♩} = 119,000397$ $\text{♩} = 121,001289$ $\text{♩} = 120,000000$ $\text{♩} = 119,000397$

6 **2** **2**

72

76

82

86

$\text{♩} = 116,000313$ $\text{♩} = 114,002335$ $\text{♩} = 119,000397$

91

95

100

104

109

Percussion

Nina Simone - My Baby Just Cares For Me 3

♩ = 118,002220

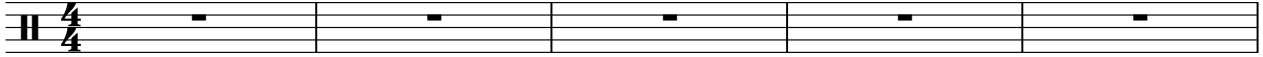

6



9



12



15



18



21

♩ = 116,000313

♩ = 119,000397



25



28



31



V.S.

2

Percussion

34



37



40



43



46



49



52

$\text{♩} = 120,000000 = 121,000000 \text{ or } 123,0022$



56 $\text{♩} = 119,000397$



59

$\text{♩} = 118,002220$



62



Percussion

65

♩ = 119,000397 ♩ = 120,000000 ♩ = 121,004089



68 ♩ = 122,001808

♩ = 120,000000 ♩ = 119,000397



71



74



77



80



83



86 ♩ = 116,000313 ♩ = 114,002335 ♩ = 119,000397



90



93



V.S.

96



99



103



106



108



109

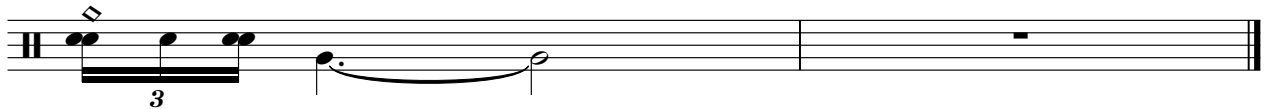

♩ = 118,002220

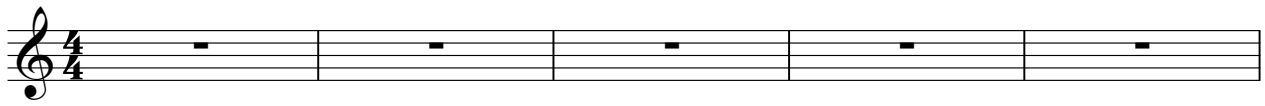

6



11



16



21

♩ = 116,000313 ♩ = 119,000397



27



33



38

♩ = 120,0010040822,00B3082

13



Kora

56 ♩ = 119,000397

♩ = 118,002220

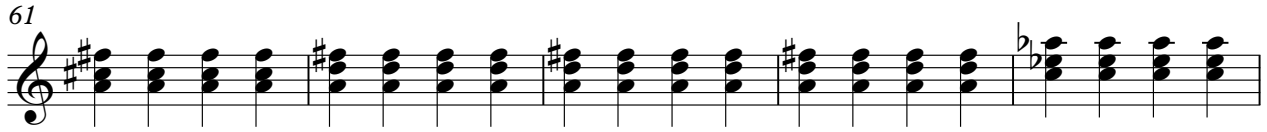

66 ♩ = 119,000397 ♩ = 121,004089 ♩ = 122,001808

♩ = 120,000397

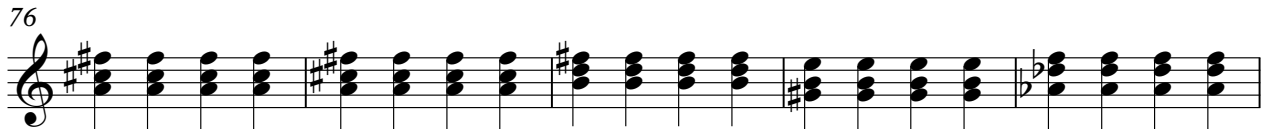
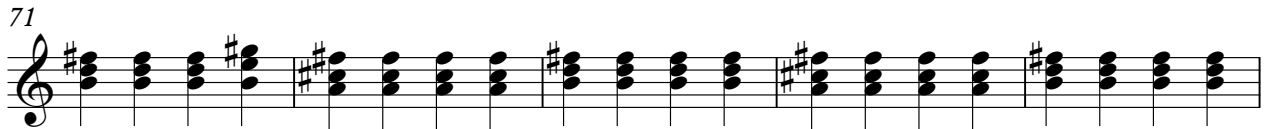
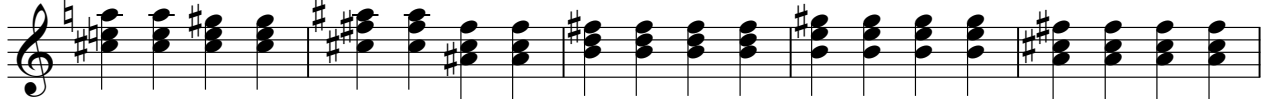

86 ♩ = 116,000313 ♩ = 114,002335 ♩ = 119,000397

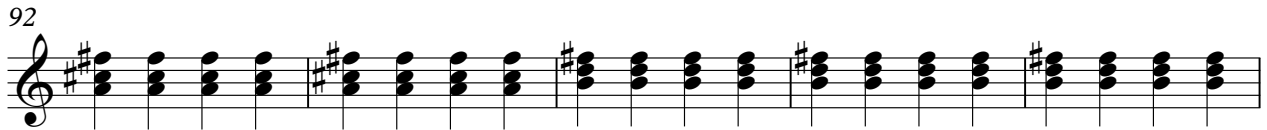
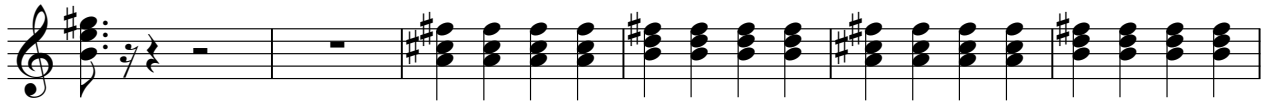

106

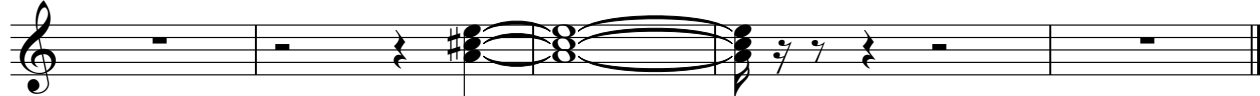

Nina Simone - My Baby Just Cares For Me 3

Acoustic Bass

♩ = 118,002220

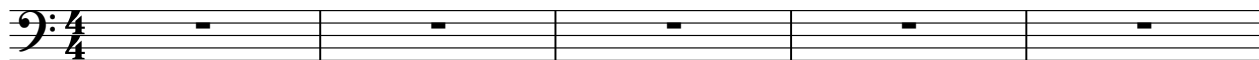

6



11



16



21

♩ = 116,000313

♩ = 119,000397

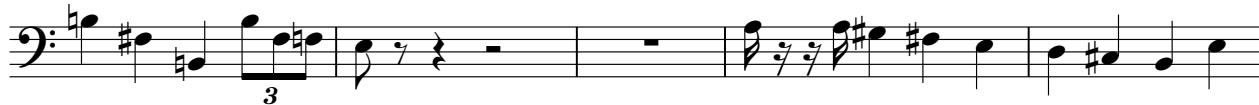

26



31



36



40



42



V.S.

44

47

52

$\text{♩} = 120,000000$ $\text{♩} = 122,001808$ $\text{♩} = 119,000397$

57

$\text{♩} = 118,002220$

61

66

$\text{♩} = 119,001327$ $\text{♩} = 120,000000$ $\text{♩} = 121,004089$ $\text{♩} = 122,001808$ $\text{♩} = 120,000000$ $\text{♩} = 119,000397$

71

76

81

86

$\text{♩} = 116,000313$ $\text{♩} = 114,002335$ $\text{♩} = 119,000397$

91



96



101



105



109

2

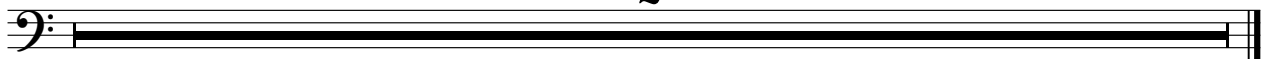

Nina Simone - My Baby Just Cares For Me 3

Solo

♩ = 118,002220

5

11

17 $\text{♩} = 116,000313$

23 $\text{♩} = 119,000397$

29

35

41

45 **2**

49

6

53

♩ = 120,000000,004082,001808,002235,000397

6 3

60

♩ = 118,002220 ♩ = 119,000397 ♩ = 120,000000

4 6 3

67

♩ = 121,004089 ♩ = 122,001808

6 6 6 6 6 6

70

♩ = 120,000000 = 119,000397

75

81

♩ = 116,000313

87

♩ = 114,002335 ♩ = 119,000397

93

5

102

3

105

Musical notation for measures 105-108. Measure 105 features a treble clef and a series of eighth notes. Measure 106 contains a whole rest. Measure 107 is filled with a complex sequence of eighth notes, including some with sharps. Measure 108 concludes with a double bar line and a guitar-specific notation consisting of a series of horizontal lines on a staff, likely representing a fretboard diagram or a specific guitar technique.

109

Musical notation for measure 109. The measure begins with a treble clef and a whole rest. The rest of the measure is empty, ending with a double bar line. Below the staff, there is a vertical line with several horizontal tick marks, which is a common notation for a guitar fretboard diagram.

Nina Simone - My Baby Just Cares For Me 3

Solo

♩ = 118,002220

5

7

9

11

13

15

17

19

♩ = 116,000313

21

Detailed description: This is a guitar solo score for the song 'My Baby Just Cares For Me' by Nina Simone. The piece is in 4/4 time and consists of 21 measures. The first measure is a whole rest. Measures 2-4 are also whole rests. From measure 5 onwards, the music features a rhythmic pattern of eighth notes, often beamed in pairs. The chords are primarily triads and dyads, with a key signature of one sharp (F#). The tempo is marked as 118,002220. At measure 21, the tempo changes to 116,000313. The solo concludes with a final chord in measure 21 followed by two whole rests.

24 ♩ = 119,000397

♩ = 120,000000 ♩ = 121,004089 ♩ = 122,001808 ♩ = 123,002235 ♩ = 119,000397

54 

57 

60 ♩ = 118,002220 

64 ♩ = 119,000397 ♩ = 120,000000 

67 ♩ = 121,004089 ♩ = 122,001808 

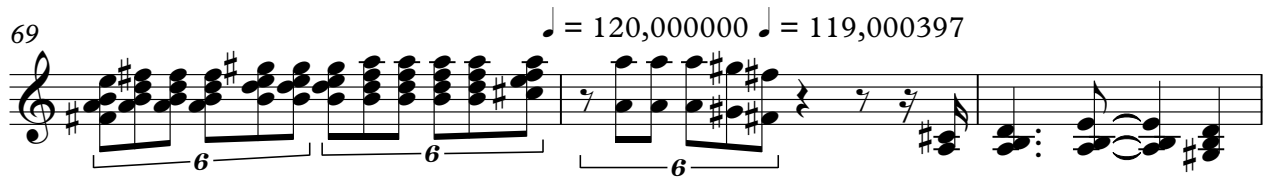
69 ♩ = 120,000000 ♩ = 119,000397 

72 

74 

76 

78 

109

The image shows a musical score for a guitar solo. It begins with a treble clef and a guitar chord diagram for a barre at the first fret, with the index finger on the first string, middle on the second, ring on the third, and pinky on the fourth. The main staff contains a fermata over a whole note, followed by a bar line and another whole note. The piece concludes with a double bar line.