

Le ore piccole - Neffa

♩ = 118,000137

Alto Saxophone

Trombone

Bass in C

Percussion

Jazz Guitar

Upright Bass

Synth Brass

Synth Strings

Lead 3 (Calliope)

Violoncello

Solo

"LE ORE PICCOLE" (Neffa) Syncro By IVAN WWW.



5

Alto Sax.

Perc.

J. Gtr.

Lead 3

Solo

LOVE MUSIC.IT Fac cio le o re

(C) 1998 by M-LIVE s.r.l.;Edizioni "20o Esaurimento Nervoso" Sanremo 2004
 (C) 1998 by M-LIVE s.r.l.;Edizioni "20o Esaurimento Nervoso" Sanremo 2004

8

Alto Sax. pic co le da quan do non ho te e,

Perc. *(triplets)*

J. Gtr. *(triplets)*

Lead 3

Solo



11

Alto Sax. fi nal men te ho il tem po che mi ser ve per pen sa

Perc. *(triplets)*

J. Gtr. *(triplets)*

Lead 3

Solo



14

Alto Sax. re sol tan to a me e an che se non ris pon do piu' al te le fo no,

Perc. *(triplets)*

J. Gtr. *(triplets)*

Syn. Str.

Lead 3

Vc. *(basso continuo)*

Solo *(triplets)*

17

Alto Sax. e l'ho det to ai miei a mi ci e non mi cre do no,

Perc.

J. Gtr.

Syn. Str.

Lead 3

Vc.

Solo



19

Alto Sax. io sto be ne da quan do non ho

Perc.

J. Gtr.

Syn. Str.

Lead 3

Vc.

Solo

21

te e uh uh uh uh uh

Musical score for measures 21-22. The score includes parts for Alto Sax, Perc., J. Gtr., U. Bass, Syn. Br., Syn. Str., Lead 3, Vc., and Solo. The Alto Sax part has lyrics "te e" followed by "uh uh uh uh uh". The Percussion part features a complex rhythmic pattern with triplets. The J. Gtr. part has a rhythmic accompaniment with triplets. The U. Bass part has a bass line with triplets. The Syn. Br. part has a melodic line with a sextuplet and triplets. The Syn. Str. part has a sustained chord. The Lead 3 part has a melodic line with triplets. The Vc. part has a sustained chord. The Solo part has a melodic line with triplets.



23

Non ci so no re go le li ti e po

Musical score for measures 23-24. The score includes parts for Alto Sax, Tbn., Bass, Perc., J. Gtr., U. Bass, Lead 3, and Solo. The Alto Sax part has lyrics "Non ci so no re go le li ti e po". The Tbn. part has a melodic line. The Bass part has a bass line. The Percussion part features a complex rhythmic pattern with triplets. The J. Gtr. part has a rhythmic accompaniment with triplets. The U. Bass part has a bass line with triplets. The Lead 3 part has a melodic line with triplets. The Solo part has a melodic line with triplets.

26

Alto Sax. le ri che ho ri pre so

Tbn.

Bass

Perc. 3 3 3 3

J. Gtr.

U. Bass

Lead 3 3

Solo

28

Alto Sax. la rou tine di sem pre, non c'e' nien

Tbn.

Bass

Perc. 3 3 3 3

J. Gtr.

U. Bass

Syn. Br.

Lead 3 3

Solo

30

Alto Sax. te che cam bie te e co si' men tre i gior

Tbn.

Bass

Perc.

J. Gtr.

U. Bass

Syn. Br.

Lead 3

Solo



32

Alto Sax. ni ri pe to e la bar ba lun

Tbn.

Bass

Perc.

J. Gtr.

U. Bass

Lead 3

Solo

34

Alto Sax. *ga priu del so li io sto be ne da quan*

Tbn.

Bass

Perc.

J. Gtr.

U. Bass

Syn. Str.

Lead 3

Vc.

Solo



36

Alto Sax. *do no on ho te e*

Perc.

J. Gtr.

U. Bass

Syn. Str.

Lead 3

Vc.

Solo

38

Alto Sax. uh uh uh uh uh uh uh Ec cet to quei mo

Tbn.

Bass

Perc.

J. Gtr.

U. Bass

Syn. Br.

Syn. Str.

Lead 3

Vc.

Solo



40

Alto Sax. men ti in cui non so di re co sa mi suc

Perc.

J. Gtr.

U. Bass

Syn. Str.

Lead 3

Vc.

Solo

42

Alto Sax.

Tbn. ce de e per che_ e' res to sen za or go

Bass

Perc.

J. Gtr.

U. Bass

Syn. Str.

Lead 3

Vc.

Solo



44

Alto Sax.

Tbn. glio e pen so an to ti vorr e i,

Bass

Perc.

J. Gtr.

U. Bass

Lead 3

Solo

46

Alto Sax.

Tbn. *quan to ti vor re i, (Stru*

Perc.

J. Gtr. *6 6 6*

U. Bass

Syn. Str.

Lead 3

Vc.

Solo



49

Alto Sax.

Tbn. *bimn 4.*

Bass

Perc.

J. Gtr. *3 3 3*

U. Bass

Syn. Str.

Vc.

Solo

53

Alto Sax. E an che se non ris pon

Tbn.

Perc.

J. Gtr.

U. Bass

Syn. Str.

Lead 3

Vc.

Solo

56

Alto Sax. do piu' al te le fo no e l'ho det to di miei a mi ci non ci cre de no

Tbn.

Bass

Perc.

J. Gtr.

U. Bass

Syn. Br.

Syn. Str.

Lead 3

Vc.

Solo

59

Alto Sax.

Tbn.

Bass

Perc.

J. Gtr.

U. Bass

Syn. Br.

Syn. Str.

Lead 3

Vc.

Solo

61

Alto Sax.

Tbn.

Bass

Perc.

J. Gtr.

U. Bass

Syn. Br.

Syn. Str.

Lead 3

Vc.

Solo

be ne da quan do trop po_ o

63

Alto Sax. *be_ e_ e_ e_ ne da quan do non ho te eh eh eh eh eh eh eh eh eh eh*

Tbn.

Bass

Perc.

J. Gtr.

U. Bass

Syn. Br.

Syn. Str.

Lead 3

Vc.

Solo



66

Alto Sax.

Perc. *eh eh*

J. Gtr.

U. Bass

Syn. Str.

Lead 3

Vc.

Solo

68

Perc.



U. Bass

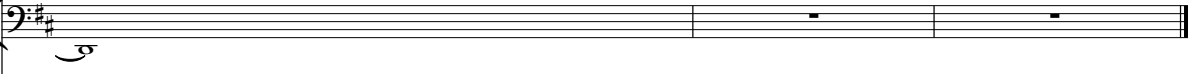

Syn. Str.



Vc.



Solo



Alto Saxophone Le ore piccole - Neffa

♩ = 118,000137 2

"LE ORE PICCOLE" (Neffa) Sincronizzato da IVAN WWW. LOMUSIC.IT Fautore

8

picole duno no hote_e, finalro iltempo che nser ve ppra res~~o~~antoane

15

e ~~ab~~enonon pia telfo, ~~Et~~atoinicini ~~ec~~onno, istbe~~n~~duan do noho tee

22

uhhhh Naino re gde liro le mi che haprao

28

lroune diem pre, nolien te cham bie re i ecosim~~g~~iior

32

ni si ri peto no elbaba elun gpiu' del soli to istbe ~~n~~duan

36

do non hote_e uhhhhhh uh Eccupia menicuoso dre casiuc chee'

43

res terza orgo glio pen so quantore i, quantore re i,

48

(Stru men ta

51

(c) 1998 by M-LIVE s.r.l.;Edizioni "20o Esaurimento Nervoso" Sanremo 2004 1.
(C) 1998 by M-LIVE s.r.l.;Edizioni "20o Esaurimento Nervoso" Sanremo 2004

Alto Saxophone

55

Edi non rison puto fo no e l'ho to ai miei ci e non cre do no

59

che be ne quan do molto be ne quan trop po_o bee_e_end quan

64

do non ho te ehehehehehehh eh eh

Trombone Le ore piccole - Neffa

♩ = 118,000137

21

26

32

39

45

50

54

58

62

70

(C) 1998 by M-LIVE s.r.l.;Edizioni "20o Esaurimento Nervoso" Sanremo 2004
(C) 1998 by M-LIVE s.r.l.;Edizioni "20o Esaurimento Nervoso" Sanremo 2004

Percussion

Le ore piccole - Neffa

♩ = 118,000137

4

6

8

10

12

14

16

18

20

(C) 1998 by M-LIVE s.r.l.;Edizioni "20o Esaurimento Nervoso" Sanremo 2004
(C) 1998 by M-LIVE s.r.l.;Edizioni "20o Esaurimento Nervoso" Sanremo 2004

V.S.

Percussion

Musical score for Percussion, measures 22-40. The score is written on a single staff with a double bar line at the beginning. It features a complex rhythmic pattern with many triplets and rests. Measure numbers 22, 24, 26, 28, 30, 32, 34, 36, 38, and 40 are indicated at the start of their respective lines. The notation includes eighth and sixteenth notes, rests, and various percussion symbols like 'x' and 'o'.

Percussion

Musical score for Percussion, measures 42-68. The score is written on a single staff with a double bar line at the beginning. It features a variety of rhythmic patterns and articulations:

- Measures 42-43:** Triplet patterns of eighth notes.
- Measures 44-45:** Triplet patterns of eighth notes.
- Measures 46-47:** A dense sixteenth-note pattern, followed by a sixteenth-note triplet.
- Measures 48-51:** A series of eighth notes with 'x' marks above them, indicating a specific articulation.
- Measures 52-55:** Eighth notes with 'x' marks, continuing the articulation pattern.
- Measures 56-58:** Eighth notes with 'x' marks, continuing the articulation pattern.
- Measures 59-62:** A complex rhythmic pattern involving eighth and sixteenth notes, with a triplet of eighth notes at the end.
- Measures 63-65:** Triplet patterns of eighth notes.
- Measures 66-67:** Triplet patterns of eighth notes, followed by a sixteenth-note triplet.
- Measures 68:** Triplet patterns of eighth notes.

♩ = 118,000137

(C) 1998 by M-LIVE s.r.l.;Edizioni "20o Esaurimento Nervoso" Sanremo 2004
(C) 1998 by M-LIVE s.r.l.;Edizioni "20o Esaurimento Nervoso" Sanremo 2004

V.S.

Upright Bass

Le ore piccole - Neffa

♩ = 118,000137

20

24

29

34

39

44

49

54

59

64

(C) 1998 by M-LIVE s.r.l.;Edizioni "20o Esaurimento Nervoso" Sanremo 2004
(C) 1998 by M-LIVE s.r.l.;Edizioni "20o Esaurimento Nervoso" Sanremo 2004

2

Upright Bass

70

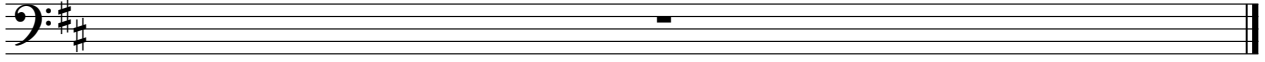

Synth Brass

Le ore piccole - Neffa

♩ = 118,000137

20

23

38

45

60

61

63

70

(C) 1998 by M-LIVE s.r.l.;Edizioni "20o Esaurimento Nervoso" Sanremo 2004
(C) 1998 by M-LIVE s.r.l.;Edizioni "20o Esaurimento Nervoso" Sanremo 2004

Synth Strings

Le ore piccole - Neffa

♩ = 118,000137

12

18

36

43

51

58

64

70

(C) 1998 by M-LIVE s.r.l.;Edizioni "20o Esaurimento Nervoso" Sanremo 2004
(C) 1998 by M-LIVE s.r.l.;Edizioni "20o Esaurimento Nervoso" Sanremo 2004

Lead 3 (Calliope) Le ore piccole - Neffa

♩ = 118,000137

5

10

14

18

22

26

30

34

38

41

(C) 1998 by M-LIVE s.r.l.;Edizioni "20o Esaurimento Nervoso" Sanremo 2004
(C) 1998 by M-LIVE s.r.l.;Edizioni "20o Esaurimento Nervoso" Sanremo 2004

V.S.

2

Lead 3 (Calliope)

45

7

55

59

63

65

3

3

70

Violoncello

Le ore piccole - Neffa

♩ = 118,000137

12

18

35

41

49

55

61

66

70

(C) 1998 by M-LIVE s.r.l.;Edizioni "20o Esaurimento Nervoso" Sanremo 2004
(C) 1998 by M-LIVE s.r.l.;Edizioni "20o Esaurimento Nervoso" Sanremo 2004

Solo

Le ore piccole - Neffa

♩ = 118,000137

5

8

15

20

23

27

(C) 1998 by M-LIVE s.r.l.;Edizioni "20o Esaurimento Nervoso" Sanremo 2004
(C) 1998 by M-LIVE s.r.l.;Edizioni "20o Esaurimento Nervoso" Sanremo 2004

30



33

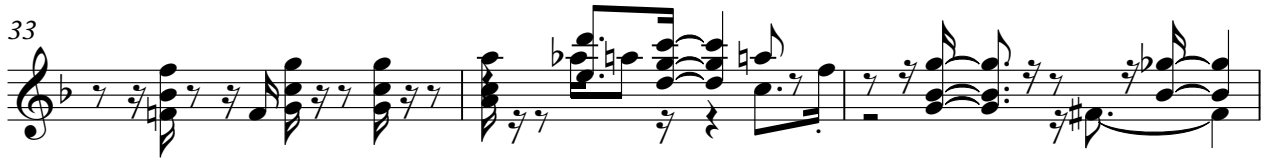

36



38



41



44



50



54



57



60



Solo

65

Musical notation for measures 65 and 66. Measure 65 features a complex rhythmic pattern with eighth and sixteenth notes, including triplets and slurs. Measure 66 continues with similar rhythmic complexity, ending with a double bar line.

67

Musical notation for measures 67, 68, and 69. Measure 67 has a melodic line with eighth notes and slurs. Measure 68 continues the melodic development. Measure 69 concludes the section with a final note and a double bar line.

70

Musical notation for measure 70, which consists of a single whole note chord on a five-line staff.