

Ricky Martin - She Bangs 2

♩ = 145,000031

This musical score is for the song 'She Bangs 2' by Ricky Martin. It is written in 4/4 time with a tempo of 145 BPM. The score includes parts for Alto Sax, Tenor Sax, Baritone Sax, Trumpet, Trombone, drummix, Steelstr. Gt., Overdrive Gt., Nylonstr. Gt., Fingered Bs., Choir Aahs, Vocal, Brass 1, and Bright Piano. The vocal line features the lyrics '2000' and '2000' with a note that says 'midimusic'. The score is divided into two systems, with a tempo change of 145,000031 indicated at the beginning of the second system.

2

3

drummix

Nylonstr. Gt.

Fingered Bs.

Vocal



5

drummix

Fingered Bs.

Vocal

6

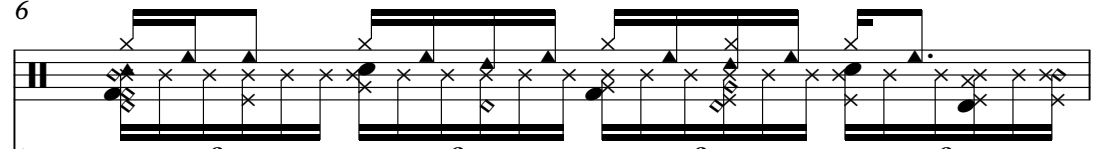

drummix

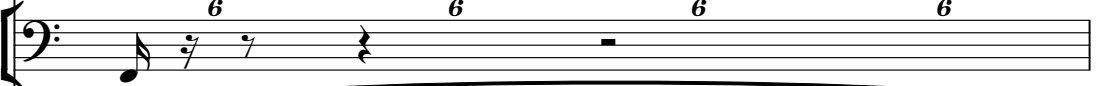

Fingered Bs.

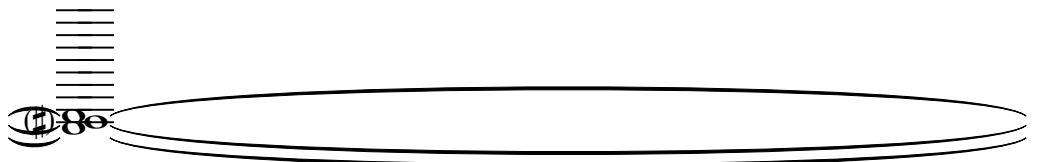

Vocal



7

drummix

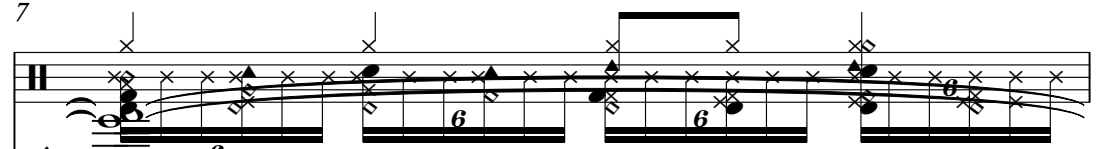

Vocal

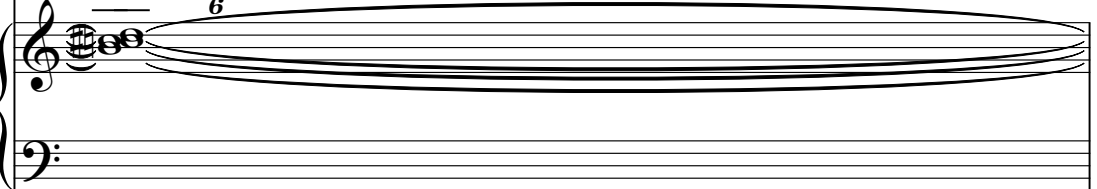

8

drummix

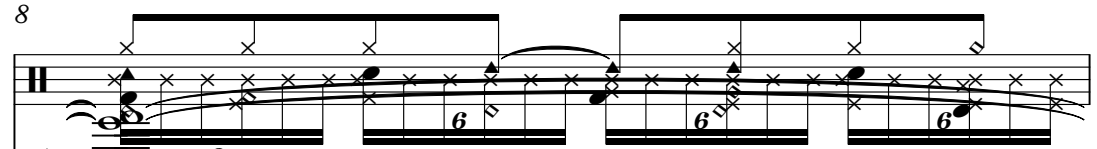

Vocal

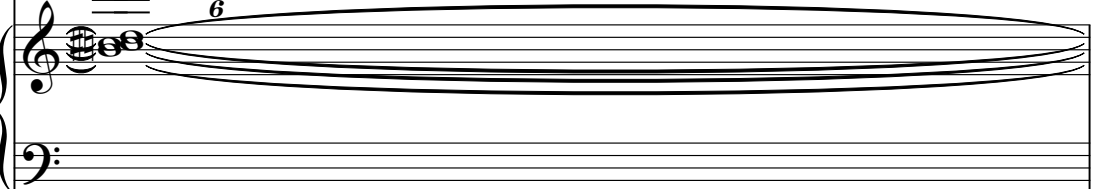

9

drummix

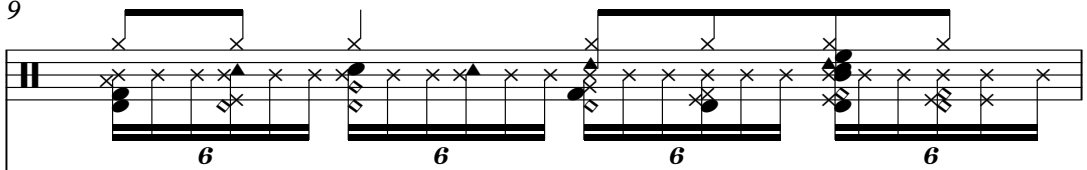

Vocal

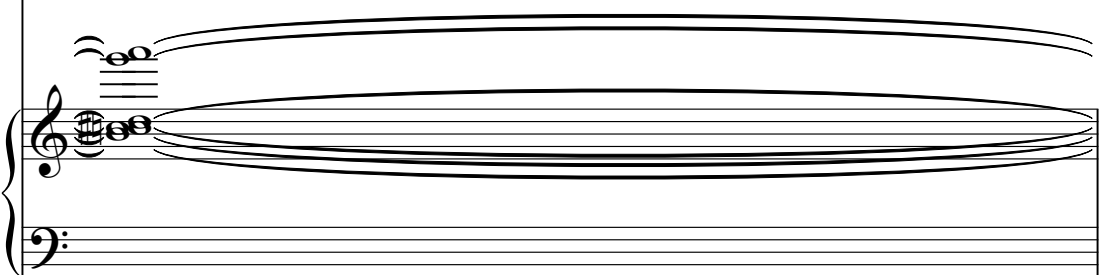

Brass 1

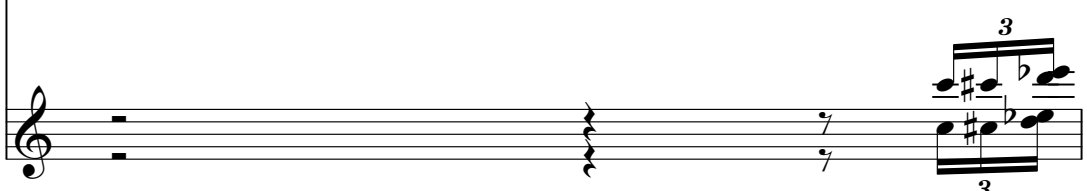

10

Alto Sax

Trumpet

drummix

Steelstr. Gt.

Overdrive Gt.

Fingered Bs.

Vocal

Brass 1

Bright Piano

11

Alto Sax

Trumpet

drummix

Steelstr. Gt.

Overdrive Gt.

Fingered Bs.

Vocal

Brass 1

Bright Piano

Detailed description: This is a page of a musical score, page 6, starting at measure 11. The score is arranged in a vertical stack of staves. From top to bottom, the staves are: Alto Sax (treble clef), Trumpet (treble clef), drummix (drum set notation), Steelstr. Gt. (treble clef), Overdrive Gt. (treble clef), Fingered Bs. (bass clef), Vocal (treble and bass clefs), Brass 1 (treble clef), and Bright Piano (treble clef). The Alto Sax and Trumpet parts feature melodic lines with various note values and rests. The drummix part shows a complex rhythmic pattern with many 'x' marks indicating hits. The Steelstr. Gt. part consists of chords and single notes. The Overdrive Gt. part has a melodic line with some bends. The Fingered Bs. part has a bass line with notes and rests. The Vocal part shows a melodic line with a long note and a rest. The Brass 1 part has a melodic line with notes and rests. The Bright Piano part has a complex accompaniment with many notes and rests.

13

Alto Sax

Trumpet

drummix

Steelstr. Gt.

Fingered Bs.

Vocal

Brass 1

Bright Piano

Detailed description: This is a page of a musical score, page 7, starting at measure 13. The score is arranged in a vertical stack of staves. From top to bottom, the staves are: Alto Sax (treble clef), Trumpet (treble clef), drummix (drum set notation), Steelstr. Gt. (treble clef), Fingered Bs. (bass clef), Vocal (treble and bass clefs), Brass 1 (treble clef), and Bright Piano (treble clef). The Alto Sax, Trumpet, and Fingered Bs. parts feature melodic lines with eighth and sixteenth notes. The drummix part shows a complex rhythmic pattern with various drum sounds. The Steelstr. Gt. part consists of chords and arpeggios. The Vocal part has long, sustained notes with a fermata. The Brass 1 part has a melodic line with some rests. The Bright Piano part provides a harmonic accompaniment with chords and arpeggios.

15

Alto Sax

Trumpet

Trombone

drummix

Steelstr. Gt.

Overdrive Gt.

Fingered Bs.

Vocal

Brass 1

Bright Piano

Detailed description: This is a page of a musical score, page 8, starting at measure 15. The score is arranged in a multi-staff format. The instruments and parts are: Alto Sax (treble clef), Trumpet (treble clef), Trombone (bass clef), drummix (drum notation), Steelstr. Gt. (treble clef, chordal), Overdrive Gt. (treble clef, melodic), Fingered Bs. (bass clef, melodic), Vocal (treble and bass clefs, sustained notes), Brass 1 (treble clef, melodic), and Bright Piano (treble clef, accompaniment). The music is in a 4/4 time signature. Measure 15 shows the beginning of the instrumental parts, with the vocal part starting in measure 16. The score includes various musical notations such as notes, rests, accidentals, and dynamic markings.

17

Alto Sax

Trumpet

Trombone

drummix

Steelstr. Gt.

Fingered Bs.

Vocal

Brass 1

Bright Piano

Detailed description: This is a page of a musical score, page 9, starting at measure 17. The score is arranged in a vertical stack of staves. From top to bottom, the staves are: Alto Sax (treble clef), Trumpet (treble clef), Trombone (bass clef), drummix (percussion clef), Steelstr. Gt. (treble clef), Fingered Bs. (bass clef), Vocal (treble and bass clefs), Brass 1 (treble clef), and Bright Piano (treble clef). The Alto Sax, Trumpet, and Fingered Bs. parts feature melodic lines with eighth and quarter notes. The Trombone part consists of block chords. The drummix part shows a complex rhythmic pattern with various drum symbols. The Steelstr. Gt. part plays a series of chords. The Vocal part has a long, sustained note with a fermata. The Brass 1 part includes a triplet of eighth notes. The Bright Piano part provides harmonic support with chords and moving lines.

18

drummix

Steelstr. Gt.

Overdrive Gt.

Fingered Bs.

Choir Aahs

Vocal

Talk to me

Brass 1

Bright Piano

19

drummix

Steelstr. Gt.

Fingered Bs.

Choir Aahs

Vocal

Tell me your name

You blow me off like it's all

Bright Piano

21

drummix

Steelstr. Gt.

Fingered Bs.

Vocal

the same

You lit a fuse and now I'm

Bright Piano

23

drummix

Steelstr. Gt.

Fingered Bs.

Choir Aahs

Vocal

ti cking a way Like a bomb Ye ah, Ba

Bright Piano

25

drummix

Steelstr. Gt.

Overdrive Gt.

Fingered Bs.

Choir Aahs

Vocal

Bright Piano

The musical score is arranged in a vertical stack of staves. The top staff is for 'drummix' and contains a complex rhythmic pattern with many 'x' marks above the notes. The second staff is 'Steelstr. Gt.' with a series of chords and some melodic lines. The third staff is 'Overdrive Gt.' which is mostly silent with a few notes in the second measure. The fourth staff is 'Fingered Bs.' with a melodic line in the bass clef. The fifth staff is 'Choir Aahs' with a vocal line. The sixth staff is 'Vocal' with lyrics 'by' and 'Talk to me'. The seventh staff is 'Bright Piano' with a complex piano accompaniment.

27

drummix

Steelstr. Gt.

Fingered Bs.

Choir Aahs

Vocal

Tell me your sign

You're switch ing sides like a

Bright Piano



29

drummix

Steelstr. Gt.

Fingered Bs.

Vocal

Ge mi ni

Bright Piano

30

drummix

Steelstr. Gt.

Fingered Bs.

Vocal

Bright Piano

You're playing games and now you're



31

drummix

Steelstr. Gt.

Fingered Bs.

Choir Aahs

Vocal

Bright Piano

hi ttin' my heart Like a drum Yeah, Ba

33

drummix

Steelstr. Gt.

Overdrive Gt.

Fingered Bs.

Choir Aahs

Vocal

by Well if La dy Luck gets

Bright Piano

35

drummix

Steelstr. Gt.

Overdrive Gt.

Fingered Bs.

Choir Aahs

Vocal

on my side We're gon na

Bright Piano

36

drummix

Steelstr. Gt.

Overdrive Gt.

Nylonstr. Gt.

Fingered Bs.

Choir Aahs

Vocal

Bright Piano

rock this town a live I'll let her

38

drummix

Steelstr. Gt.

Overdrive Gt.

Nylonstr. Gt.

Fingered Bs.

Choir Aahs

Vocal

Bright Piano

40

Trumpet

drummix

Steelstr. Gt.

Fingered Bs.

Choir Aahs

Vocal

Brass 1

Bright Piano

walks like she talks, And she talks like she walks she

3

3

Detailed description: This page of a musical score contains measures 40 through 43. The score is arranged in a grand staff format with eight staves. From top to bottom, the staves are: Trumpet (treble clef), drummix (percussion clef), Steelstr. Gt. (treble clef), Fingered Bs. (bass clef), Choir Aahs (treble clef), Vocal (treble and bass clefs), Brass 1 (treble clef), and Bright Piano (treble clef). Measure 40 is marked with a '40' above the first staff. The vocal line includes lyrics: 'walks like she talks, And she talks like she walks she'. There are two triplet markings (indicated by a '3' above a bracket) in the vocal line, one over the notes 'like she walks' in measure 41 and another over 'she' in measure 42. The Brass 1 staff features large oval markings over the notes in measures 41 and 42. The drummix staff shows a complex rhythmic pattern with various drum symbols. The other instruments provide harmonic support with chords and melodic lines.

42

Tenor Sax

Trumpet

Trombone

drummix

Steelstr. Gt.

Overdrive Gt.

Fingered Bs.

Choir Aahs

Vocal

brangs, she brangs

Oh ba by she

Brass 1

Bright Piano

44

Tenor Sax

Trumpet

Trombone

drummix

Steelstr. Gt.

Overdrive Gt.

Fingered Bs.

Choir Aahs

Vocal

moves, she moves I ,go cra zy 'Cause she

Brass 1

Bright Piano

Detailed description: This is a page of a musical score, page 22, starting at measure 44. The score is arranged in a vertical stack of staves. From top to bottom, the parts are: Tenor Sax (treble clef), Trumpet (treble clef), Trombone (bass clef), drummix (percussion clef), Steelstr. Gt. (treble clef), Overdrive Gt. (treble clef), Fingered Bs. (bass clef), Choir Aahs (treble clef), Vocal (treble and bass clefs), Brass 1 (treble clef), and Bright Piano (treble clef). The vocal line includes the lyrics: "moves, she moves I ,go cra zy 'Cause she". The score features various musical notations including notes, rests, accidentals, and dynamic markings.

46

Trumpet

drummix

Steelstr. Gt.

Overdrive Gt.

Fingered Bs.

Choir Aahs

Vocal

looks like a flower but she stings like a bee

Brass 1

Bright Piano

Detailed description: This is a page of a musical score, page 23, starting at measure 46. The score is arranged in a vertical stack of staves. From top to bottom, the staves are: Trumpet (treble clef), drummix (percussion clef), Steelstr. Gt. (treble clef), Overdrive Gt. (treble clef), Fingered Bs. (bass clef), Choir Aahs (treble clef), Vocal (treble and bass clefs), Brass 1 (treble clef), and Bright Piano (treble clef). The vocal line includes the lyrics 'looks like a flower but she stings like a bee'. The score features various musical notations such as notes, rests, accidentals, and dynamic markings.

48

Tenor Sax

Trumpet

Trombone

drummix

Steelstr. Gt.

Fingered Bs.

Choir Aahs

Vocal

Brass 1

Bright Piano

Like e very girl in his to ry

50

Alto Sax

Trumpet

Trombone

drummix

Steelstr. Gt.

Overdrive Gt.

Fingered Bs.

Choir Aahs

Vocal

Brass 1

Bright Piano

I'm was ted by the way she

52

Alto Sax

Trombone

drummix

Steelstr. Gt.

Overdrive Gt.

Fingered Bs.

Choir Aahs

Vocal

moves No one e ver look ed so

Brass 1

Bright Piano

54

Alto Sax

Trombone

drummix

Steelstr. Gt.

Overdrive Gt.

Fingered Bs.

Vocal

Brass 1

Bright Piano

fine

Detailed description: This is a page of a musical score for a rock band. It features ten staves. The top staff is for Alto Sax, followed by Trombone, drummix (with a drumkit icon), Steelstr. Gt. (steel string guitar), Overdrive Gt. (overdrive guitar), Fingered Bs. (fingered bass), Vocal (with a 'fine' marking), Brass 1, and Bright Piano. The score includes various musical notations such as notes, rests, accidentals, and dynamic markings. The vocal part concludes with a 'fine' marking. The drummix part uses 'x' marks to indicate drum hits. The guitar parts feature chords and melodic lines. The brass and piano parts provide harmonic support.

55

Alto Sax

Trombone

drummix

Steelstr. Gt.

Overdrive Gt.

Fingered Bs.

Vocal

She re minds me that

Brass 1

Bright Piano

56

Baritone Sax

Trumpet

Trombone

drummix

Steelstr. Gt.

Fingered Bs.

Vocal

Brass 1

Bright Piano

a wo man on ly got one thing on her mind

Detailed description: This is a page of a musical score for a jazz ensemble. The page is numbered 56 at the top left and 29 at the top right. The score is arranged in a vertical stack of staves. From top to bottom, the parts are: Baritone Sax (treble clef), Trumpet (treble clef), Trombone (bass clef), drummix (percussion clef), Steelstr. Gt. (treble clef), Fingered Bs. (bass clef), Vocal (treble and bass clefs), Brass 1 (treble clef), and Bright Piano (treble clef). The vocal line includes the lyrics "a wo man on ly got one thing on her mind". The score features various musical notations including eighth notes, quarter notes, and rests, with some notes beamed together. There are also dynamic markings and articulation symbols throughout the piece.

58

Alto Sax

Tenor Sax

Trumpet

Trombone

drummix

Overdrive Gt.

Fingered Bs.

Vocal

Brass 1

60

Alto Sax

Tenor Sax

Trumpet

Trombone

drummix

Choir Aahs

Vocal

Brass 1

Talk to me Tell me your name

Detailed description: This is a page of a musical score for a jazz ensemble. It features seven staves. The top two staves are for Alto Sax and Tenor Sax, both in treble clef. The next two are for Trumpet and Trombone, both in treble clef. The fifth staff is for drummix, using a drum set notation. The sixth staff is for Choir Aahs, in treble clef. The seventh staff is for Vocal, in treble clef, with lyrics 'Talk to me Tell me your name'. Below the vocal staff are two staves for Brass 1, in treble clef, with a large oval indicating a sustained chord. The score is numbered 60 at the top left.

62

Alto Sax

Tenor Sax

Trumpet

drummix

Steelstr. Gt.

Fingered Bs.

Vocal

I'm just a link in your dai sy chain

Brass 1

Bright Piano

64

Alto Sax

Tenor Sax

Trumpet

drummix

Steelstr. Gt.

Fingered Bs.

Vocal

Bright Piano

Your rap sounds like

Detailed description: This is a page of a musical score for a jazz ensemble. It features eight staves. The top two staves are for Alto Sax and Tenor Sax, both in treble clef. The third staff is for Trumpet, also in treble clef. The fourth staff is for drummix, using a standard drum notation. The fifth staff is for Steelstr. Gt. in treble clef. The sixth staff is for Fingered Bs. in bass clef. The seventh staff is for Vocal, with lyrics 'Your rap sounds like' written below the notes. The eighth staff is for Bright Piano, in treble clef. The music is in 4/4 time, as indicated by the '64' at the top left. The score includes various musical notations such as notes, rests, accidentals, and dynamic markings.

65

Alto Sax

Tenor Sax

Trumpet

drummix

Steelstr. Gt.

Fingered Bs.

Choir Aahs

Vocal

Brass 1

Bright Piano

a dia mond Map to the stars Ye ah, Ba

67

Alto Sax

Tenor Sax

drummix

Steelstr. Gt.

Overdrive Gt.

Fingered Bs.

Choir Aahs

Vocal

by Talk to me

Brass 1

Bright Piano

69

Alto Sax

Tenor Sax

Trumpet

drummix

Steelstr. Gt.

Fingered Bs.

Choir Aahs

Vocal

Tell me the news

You wear me out like a

Brass 1

Bright Piano

71

Alto Sax

Tenor Sax

Trumpet

drummix

Steelstr. Gt.

Fingered Bs.

Vocal

pair of shoes We'll dance un til

Brass 1

Bright Piano

73

Alto Sax

Tenor Sax

Trumpet

Trombone

drummix

Steelstr. Gt.

Fingered Bs.

Choir Aahs

Vocal

the band goes home Then you're gone Yeah, Ba

Brass 1

Bright Piano

75

Alto Sax

Trumpet

Trombone

drummix

Steelstr. Gt.

Overdrive Gt.

Fingered Bs.

Choir Aahs

Vocal

by Well if it looks like love

Brass 1

Bright Piano

77

Alto Sax

Tenor Sax

Trumpet

drummix

Steelstr. Gt.

Overdrive Gt.

Fingered Bs.

Choir Aahs

Vocal

should be_a crime You'd be tter

Brass 1

Bright Piano

78

Alto Sax

Tenor Sax

drummix

Steelstr. Gt.

Overdrive Gt.

Nylonstr. Gt.

Fingered Bs.

Choir Aahs

Vocal

lock me up for life I'll do

Brass 1

Bright Piano

80

drummix

Steelstr. Gt.

Overdrive Gt.

Nylonstr. Gt.

Fingered Bs.

Choir Aahs

Vocal

the time with a smile

Brass 1

Bright Piano

81

The musical score consists of the following parts:

- drummix**: Features a complex rhythmic pattern with various note values and rests, including some notes with 'x' marks above them.
- Steelstr. Gt.**: Plays a series of chords and single notes, some with accents.
- Overdrive Gt.**: Shows a sustained chord in the treble clef.
- Fingered Bs.**: Plays a rhythmic line of eighth notes with accents.
- Choir Aahs**: Features a melodic line with accents and a slur.
- Vocal**: Includes the lyrics "on my face Thin" with a long, sweeping melodic line.
- Brass 1**: Plays a sustained chord with a slur.
- Bright Piano**: Plays a rhythmic accompaniment with chords and single notes.

82

Trumpet

drummix

Steelstr. Gt.

Fingered Bs.

Choir Aahs

Vocal

king of her in her lea ther³ and lace she

Brass 1

Bright Piano

Detailed description: This page of a musical score, numbered 44, contains eight staves. The top staff is for Trumpet, starting at measure 82 with a series of eighth and quarter notes. The second staff is for drummix, showing a complex rhythmic pattern with various note values and rests. The third staff is for Steelstr. Gt., featuring a series of chords and single notes. The fourth staff is for Fingered Bs., with a melodic line of eighth and quarter notes. The fifth staff is for Choir Aahs, consisting of a simple melodic line. The sixth staff is for Vocal, with lyrics: "king of her in her lea ther³ and lace she". The seventh staff is for Brass 1, showing a melodic line with some rests. The eighth staff is for Bright Piano, with a rhythmic accompaniment of eighth and quarter notes.

84

Tenor Sax

Trumpet

Trombone

drummix

Steelstr. Gt.

Overdrive Gt.

Fingered Bs.

Choir Aahs

Vocal

brass, she brass Oh ba by she

Brass 1

Bright Piano

Detailed description: This is a page of a musical score, page 84 of 45. The score is arranged in a vertical stack of staves. From top to bottom, the staves are: Tenor Sax (treble clef), Trumpet (treble clef), Trombone (bass clef), drummix (drum notation), Steelstr. Gt. (treble clef), Overdrive Gt. (treble clef), Fingered Bs. (bass clef), Choir Aahs (treble clef), Vocal (treble and bass clefs), Brass 1 (treble clef), and Bright Piano (treble clef). The vocal line includes the lyrics "brass, she brass" and "Oh ba by she". The score includes various musical notations such as notes, rests, beams, and dynamic markings.

86

Tenor Sax

Trumpet

Trombone

drummix

Steelstr. Gt.

Overdrive Gt.

Fingered Bs.

Choir Aahs

Vocal

moves, she moves I ,go cra zy 'Cause she

Brass 1

Bright Piano

88

Trumpet

drummix

Steelstr. Gt.

Overdrive Gt.

Fingered Bs.

Choir Aahs

Vocal

looks like a flower but she stings like a bee

Brass 1

Bright Piano

Detailed description: This is a page of a musical score, page 47, starting at measure 88. The score is arranged in a vertical stack of staves. From top to bottom, the staves are: Trumpet (treble clef), drummix (percussion clef), Steelstr. Gt. (treble clef), Overdrive Gt. (treble clef), Fingered Bs. (bass clef), Choir Aahs (treble clef), Vocal (treble and bass clefs), Brass 1 (treble clef), and Bright Piano (treble clef). The vocal line includes the lyrics "looks like a flower but she stings like a bee". The score features various musical notations such as notes, rests, accidentals, and dynamic markings.

90

Tenor Sax

Trumpet

Trombone

drummix

Steelstr. Gt.

Fingered Bs.

Choir Aahs

Vocal

Brass 1

Bright Piano

Like e very girl in his to ry

92

Alto Sax

Trumpet

Trombone

drummix

Steelstr. Gt.

Overdrive Gt.

Fingered Bs.

Choir Aahs

Vocal

Brass 1

Bright Piano

I'm was ted by the way she

94

Alto Sax

Trombone

drummix

Steelstr. Gt.

Overdrive Gt.

Fingered Bs.

Choir Aahs

Vocal

moves No one e ver look ed so

Brass 1

Bright Piano

96

Alto Sax

Trombone

drummix

Steelstr. Gt.

Overdrive Gt.

Fingered Bs.

Vocal

fine

Brass 1

Bright Piano

97

Alto Sax

Trombone

drummix

Steelstr. Gt.

Overdrive Gt.

Fingered Bs.

Vocal

She re minds me that

Brass 1

Bright Piano

98

Baritone Sax

Trombone

drummix

Steelstr. Gt.

Fingred Bs.

Vocal

Brass 1

Bright Piano

a wo man on ly got one thing on her mind

100

The musical score for page 54, measures 100-101, features the following parts:

- Alto Sax:** Treble clef, starting with a rest in measure 100, followed by eighth notes in measure 101.
- Tenor Sax:** Treble clef, playing a melodic line with eighth notes and a slur across measures 100 and 101.
- Trumpet:** Treble clef, playing a sustained note (half note) across measures 100 and 101.
- Trombone:** Bass clef, playing a sustained note (half note) across measures 100 and 101.
- drummix:** Drum notation with various patterns of 'x' marks indicating hits.
- Steelstr. Gt.:** Treble clef, playing a rhythmic pattern of chords and single notes.
- Overdrive Gt.:** Treble clef, playing a sustained note (half note) across measures 100 and 101.
- Fingered Bs.:** Bass clef, playing a melodic line with eighth notes and a slur across measures 100 and 101.
- Vocal:** Treble and Bass clefs, both playing sustained notes (half notes) across measures 100 and 101.
- Brass 1:** Treble clef, playing a sustained note (half note) across measures 100 and 101.

102

Trumpet

drummix

Steelstr. Gt.

Overdrive Gt.

Fingered Bs.

Vocal

Brass 1

Bright Piano

Detailed description: This is a multi-staff musical score for a rock or metal band. The score is written for eight parts: Trumpet, drummix, Steelstr. Gt., Overdrive Gt., Fingered Bs., Vocal, Brass 1, and Bright Piano. The music is in a key with one flat (B-flat major or D minor) and a 4/4 time signature. The Trumpet part starts at measure 102 with a few notes and rests. The drummix part features a complex, syncopated rhythm with many accents. The Steelstr. Gt. part consists of a series of chords and single notes. The Overdrive Gt. part has a fast, melodic line with many sixteenth notes. The Fingered Bs. part has a simple, rhythmic line. The Vocal part has two staves, both of which are mostly empty, suggesting a vocal line that is not fully written out. The Brass 1 part has a few notes and rests. The Bright Piano part has a complex, syncopated rhythm with many accents.

104

drummix

Steelstr. Gt.

Overdrive Gt.

Fingered Bs.

Vocal

Brass 1

Bright Piano

Detailed description: This page of a musical score, numbered 56, contains seven staves. The first staff, labeled 'drummix', starts at measure 104 and features a complex rhythmic pattern with 'x' marks above notes. The second staff, 'Steelstr. Gt.', shows a series of chords and melodic lines. The third staff, 'Overdrive Gt.', contains a few notes with a long sustain. The fourth staff, 'Fingered Bs.', has a melodic line with some accidentals. The fifth staff, 'Vocal', consists of two staves with long, empty notes and slurs. The sixth staff, 'Brass 1', has a few notes with slurs. The seventh staff, 'Bright Piano', features a complex melodic and harmonic line with many notes and slurs.

106

The musical score consists of seven staves. The **drummix** staff uses a double bar line and a series of 'x' marks to indicate drum hits. The **Steelstr. Gt.** staff features a series of chords and single notes. The **Overdrive Gt.** staff contains a melodic line with various intervals and accidentals. The **Fingered Bs.** staff shows a bass line with notes and rests. The **Vocal** section is represented by two staves with large oval shapes, indicating sustained notes or breath marks. The **Brass 1** staff shows a few notes and rests. The **Bright Piano** staff features a complex melodic and harmonic line with many notes and rests.

108

Trumpet

drummix

Steelstr. Gt.

Overdrive Gt.

Fingered Bs.

Choir Aahs

Vocal

Brass 1

Bright Piano

Well if

Detailed description: This is a multi-stem musical score for a rock or metal band. The score is divided into two systems. The first system includes Trumpet, drummix, Steelstr. Gt., Overdrive Gt., and Fingered Bs. The second system includes Choir Aahs, Vocal, Brass 1, and Bright Piano. The Trumpet and Brass 1 parts are identical, featuring a melodic line with a key signature of one sharp (F#) and a 7/8 time signature. The drummix part shows a complex rhythmic pattern with various note values and rests. The Steelstr. Gt. part consists of a series of chords and single notes. The Overdrive Gt. part features a fast, melodic line with many sixteenth notes. The Fingered Bs. part has a steady, rhythmic bass line. The Vocal part includes the lyrics 'Well if' and is accompanied by a piano accompaniment. The Choir Aahs part consists of a few notes and rests. The Bright Piano part provides a harmonic foundation with chords and single notes.

110

Alto Sax

Trumpet

drummix

Steelstr. Gt.

Overdrive Gt.

Fingered Bs.

Choir Aahs

Vocal

La dy Luck gets on my side We're gon na

Brass 1

Bright Piano

Detailed description: This is a page of a musical score for a jazz or rock ensemble. It features ten staves. The top two staves are for Alto Sax and Trumpet, both playing a long, sustained note with a slur. The drummix staff shows a complex rhythmic pattern with various drum symbols. The Steelstr. Gt. staff has a series of chords with a rhythmic pattern. The Overdrive Gt. staff has a sustained chord. The Fingered Bs. staff has a melodic line with a key signature change. The Choir Aahs staff has a rhythmic pattern. The Vocal staff has the lyrics 'La dy Luck gets on my side We're gon na'. The Brass 1 staff has a sustained chord. The Bright Piano staff has a complex rhythmic pattern.

112

Trombone

drummix

Steelstr. Gt.

Overdrive Gt.

Fingered Bs.

Choir Aahs

Vocal

rock this town a live I'll let her

Brass 1

Bright Piano

Detailed description: This is a page of a musical score, page 60, starting at measure 112. The score is arranged in a vertical stack of staves. From top to bottom, the staves are: Trombone (bass clef), drummix (percussion clef), Steelstr. Gt. (treble clef), Overdrive Gt. (treble clef), Fingered Bs. (bass clef), Choir Aahs (treble clef), Vocal (treble and bass clefs), Brass 1 (treble clef), and Bright Piano (treble clef). The Trombone part has a few notes in the second measure. The drummix part shows a complex rhythmic pattern with many 'x' marks. The Steelstr. Gt. part features a series of chords with slash marks. The Overdrive Gt. part has a sustained chord. The Fingered Bs. part has a melodic line with slash marks. The Choir Aahs part has a simple melodic line. The Vocal part has lyrics: 'rock this town a live I'll let her'. The Brass 1 part has a few notes in the second measure. The Bright Piano part has a complex melodic line with slash marks.

114

Trumpet

Trombone

drummix

Steelstr. Gt.

Overdrive Gt.

Nylonstr. Gt.

Fingered Bs.

Choir Aahs

Vocal

rough me up Till she knocks me out She

Brass 1

Bright Piano

116

Trumpet

drummix

Steelstr. Gt.

Fingered Bs.

Choir Aahs

Vocal

Brass 1

Bright Piano

walks like she talks, And she talks like she walks

6

6

6

3

3

6

6

6

6

118

Trumpet

Trombone

drummix

Choir Aahs

Vocal

Brass 1

she

Detailed description: This is a page of a musical score, page 63, starting at measure 118. It features six staves. The Trumpet and Trombone staves are in G major (one sharp) and contain rests followed by a quarter note chord of G4, B4, D5. The drummix staff shows a pattern of sixteenth notes marked with 'x' over a bass drum line, with three groups of six notes each, each group marked with a '6'. The Choir Aahs staff has a rest followed by a quarter note chord of G4, B4, D5. The Vocal staff has a rest followed by a quarter note chord of G4, B4, D5, with the word 'she' written below. The Brass 1 staff has a rest followed by a quarter note chord of G4, B4, D5. There are also some graphical elements like a large oval shape and a series of horizontal lines above the Vocal staff.

119

Tenor Sax

Trumpet

Trombone

drummix

Steelstr. Gt.

Overdrive Gt.

Fingered Bs.

Choir Aahs

Vocal

bangs, she bangs

Oh ba by she

Brass 1

Bright Piano

121

Tenor Sax

Trumpet

Trombone

drummix

Steelstr. Gt.

Overdrive Gt.

Fingered Bs.

Choir Aahs

Vocal

moves, she moves I ,go cra zy 'Cause she

Brass 1

Bright Piano

Detailed description: This is a page of a musical score, page 65, starting at measure 121. The score is arranged in a vertical stack of staves. From top to bottom, the staves are: Tenor Sax (treble clef), Trumpet (treble clef), Trombone (bass clef), drummix (percussion clef), Steelstr. Gt. (treble clef), Overdrive Gt. (treble clef), Fingered Bs. (bass clef), Choir Aahs (treble clef), Vocal (treble and bass clefs), Brass 1 (treble clef), and Bright Piano (treble clef). The vocal line includes the lyrics: "moves, she moves I ,go cra zy 'Cause she". The score features various musical notations including notes, rests, accidentals, and dynamic markings.

123

Trumpet

drummix

Steelstr. Gt.

Overdrive Gt.

Fingered Bs.

Choir Aahs

Vocal

looks like a flower but she stings like a bee

Brass 1

Bright Piano

125

Alto Sax

Tenor Sax

Trumpet

Trombone

drummix

Steelstr. Gt.

Fingered Bs.

Choir Aahs

Vocal

Brass 1

Bright Piano

Like e very girl in his to ry

127

Alto Sax

Trumpet

Trombone

drummix

Steelstr. Gt.

Overdrive Gt.

Fingered Bs.

Choir Aahs

Vocal

Oh ba by

Brass 1

Bright Piano

129

Trombone

drummix

Steelstr. Gt.

Overdrive Gt.

Fingered Bs.

Choir Aahs

Vocal

Brass 1

Bright Piano

I go cra zy 'Cause she

Detailed description: This is a page of a musical score, page 69, starting at measure 129. The score is arranged in a vertical stack of staves. From top to bottom, the staves are: Trombone (bass clef, starting with a flat key signature), drummix (percussion clef, showing a complex rhythmic pattern with 'x' marks for cymbals), Steelstr. Gt. (treble clef, playing chords), Overdrive Gt. (treble clef, playing a melodic line with long notes and ties), Fingered Bs. (bass clef, playing a melodic line), Choir Aahs (treble clef, playing chords), Vocal (treble and bass clefs, with the lyrics 'I go cra zy 'Cause she'), Brass 1 (treble clef, playing chords), and Bright Piano (treble clef, playing chords). The vocal line includes the lyrics 'I go cra zy 'Cause she'.

131

Trombone

drummix

Steelstr. Gt.

Overdrive Gt.

Fingered Bs.

Choir Aahs

Vocal

looks like a flower but she stings like a bee

Brass 1

Bright Piano

Detailed description: This is a page of a musical score, page 70, starting at measure 131. The score is arranged in a vertical stack of staves. From top to bottom, the staves are: Trombone (bass clef, key signature of one flat), drummix (percussion clef), Steelstr. Gt. (treble clef, playing chords), Overdrive Gt. (treble clef, playing sustained notes), Fingered Bs. (bass clef, playing a melodic line), Choir Aahs (treble clef, playing chords), Vocal (treble and bass clefs, with lyrics 'looks like a flower but she stings like a bee'), Brass 1 (treble clef, playing chords), and Bright Piano (treble clef, playing chords). The music is in a 4/4 time signature. The vocal line is the central focus, with lyrics provided. The instrumental parts provide accompaniment and texture.

133

Trombone

drummix

Steelstr. Gt.

Fingered Bs.

Choir Aahs

Vocal

Like e very girl in his to ry

Brass 1

Bright Piano

Detailed description: This is a page of a musical score, page 71, starting at measure 133. The score is arranged in a grand staff format with eight staves. From top to bottom, the staves are: Trombone (bass clef), drummix (drum notation), Steelstr. Gt. (treble clef), Fingered Bs. (bass clef), Choir Aahs (treble clef), Vocal (treble and bass clefs), Brass 1 (treble clef), and Bright Piano (treble clef). The Trombone part features a melodic line with a long note in the first measure. The drummix part shows a complex rhythmic pattern with various drum sounds. The Steelstr. Gt. part consists of chords and arpeggios. The Fingered Bs. part has a melodic line with some accidentals. The Choir Aahs part has a rhythmic pattern of notes. The Vocal part has the lyrics 'Like e very girl in his to ry' with a melodic line. The Brass 1 part has a melodic line with some accidentals. The Bright Piano part has a melodic line with some accidentals.

135

Trombone

drummix

Steelstr. Gt.

Overdrive Gt.

Fingered Bs.

Choir Aahs

Vocal

I'm wasted by the way she moves

Brass 1

Bright Piano

Detailed description: This is a page of a musical score, page 72, starting at measure 135. The score is arranged in a grand staff format with nine staves. From top to bottom, the staves are: Trombone (bass clef), drummix (percussion clef), Steelstr. Gt. (treble clef), Overdrive Gt. (treble clef), Fingered Bs. (bass clef), Choir Aahs (treble clef), Vocal (treble and bass clefs), Brass 1 (treble clef), and Bright Piano (treble clef). The Trombone part begins with a rest followed by a melodic line. The drummix part features a complex rhythmic pattern with 'x' marks indicating hits. The Steelstr. Gt. part consists of a series of chords. The Overdrive Gt. part has a melodic line with a long sustain. The Fingered Bs. part has a rhythmic bass line. The Choir Aahs part has a vocal line with 'Aahs' lyrics. The Vocal part has a vocal line with the lyrics 'I'm wasted by the way she moves'. The Brass 1 part has a melodic line. The Bright Piano part has a melodic line.

137

Trombone

drummix

Steelstr. Gt.

Overdrive Gt.

Fingered Bs.

Choir Aahs

Vocal

Brass 1

Bright Piano

No one

Detailed description: This is a page of a musical score, page 73, starting at measure 137. The score is arranged in a vertical stack of staves. From top to bottom, the parts are: Trombone (bass clef, starting with a whole note B-flat), drummix (drum notation with various patterns), Steelstr. Gt. (treble clef, playing chords and single notes), Overdrive Gt. (treble clef, playing a sustained chord with a melodic line), Fingered Bs. (bass clef, playing a melodic line), Choir Aahs (treble clef, playing chords), Vocal (treble and bass clefs, with the lyrics "No one"), Brass 1 (treble clef, playing chords), and Bright Piano (treble clef, playing chords). The score includes various musical notations such as notes, rests, beams, and dynamic markings.

138

Trombone

drummix

Steelstr. Gt.

Overdrive Gt.

Fingered Bs.

Choir Aahs

Vocal

Brass 1

Bright Piano

e ver look ed so

Detailed description: This page of a musical score, numbered 74, contains measures 138 through 142. The score is arranged in a vertical stack of staves. From top to bottom, the parts are: Trombone (bass clef), drummix (percussion clef), Steelstr. Gt. (treble clef), Overdrive Gt. (treble clef), Fingered Bs. (bass clef), Choir Aahs (treble clef), Vocal (treble and bass clefs), Brass 1 (treble clef), and Bright Piano (treble clef). The Trombone part features a melodic line with notes G2, A2, B2, C3, D3, E3, and F3. The drummix part shows a complex rhythmic pattern with various drum sounds. The Steelstr. Gt. part consists of chords and single notes. The Overdrive Gt. part has a sustained chord. The Fingered Bs. part has a simple bass line. The Choir Aahs part has a rhythmic pattern of notes. The Vocal part has the lyrics 'e ver look ed so' under the notes. The Brass 1 part has a melodic line with notes G2, A2, B2, C3, D3, E3, and F3. The Bright Piano part has a simple bass line.

139

Trombone

drummix

Steelstr. Gt.

Overdrive Gt.

Fingered Bs.

Choir Aahs

Vocal

Brass 1

Bright Piano

fine She re minds

Detailed description: This is a page of a musical score, page 75, starting at measure 139. The score is arranged in a grand staff format with nine staves. From top to bottom, the staves are: Trombone (bass clef), drummix (percussion clef), Steelstr. Gt. (treble clef), Overdrive Gt. (treble clef), Fingered Bs. (bass clef), Choir Aahs (treble clef), Vocal (treble and bass clefs), Brass 1 (treble clef), and Bright Piano (treble clef). The Trombone part begins with a whole note chord of B-flat and D-flat. The drummix part features a complex rhythmic pattern with various drum sounds. The Steelstr. Gt. part consists of a series of chords and single notes. The Overdrive Gt. part has a melodic line with some sustained notes. The Fingered Bs. part has a melodic line with some chromaticism. The Choir Aahs part has a simple melodic line. The Vocal part has a melodic line with the lyrics 'fine' and 'She re minds'. The Brass 1 part has a melodic line with some sustained notes. The Bright Piano part has a melodic line with some chromaticism.

141

Trombone

drummix

Steelstr. Gt.

Fingered Bs.

Choir Aahs

Vocal

me that a wo man only got one

Brass 1

Bright Piano

Detailed description: This page of a musical score, numbered 76, contains measures 141 through 144. The score is arranged in a grand staff format with eight staves. The Trombone staff (bass clef) features a long note with a flat and a slur over the first measure, followed by a melodic line. The drummix staff (percussion clef) shows a complex rhythmic pattern with various note values and rests. The Steelstr. Gt. staff (treble clef) plays a series of chords, some with slurs. The Fingered Bs. staff (bass clef) has a simple melodic line. The Choir Aahs staff (treble clef) consists of rhythmic patterns. The Vocal staff (treble clef) has the lyrics 'me that a wo man only got one' with notes and rests. The Brass 1 staff (treble clef) has a melodic line with slurs. The Bright Piano staff (treble clef) has a melodic line with slurs. The page number '76' is at the top left, and the measure number '141' is at the top of the first staff.

142

Tenor Sax

Baritone Sax

Trumpet

Trombone

drummix

Steelstr. Gt.

Fingered Bs.

Choir Aahs

Vocal

thing on her mind

Brass 1

Bright Piano

Detailed description: This is a page of a musical score, page 77, starting at measure 142. The score is arranged in a grand staff format with multiple parts. The instruments and parts include Tenor Sax, Baritone Sax, Trumpet, Trombone, drummix, Steelstr. Gt., Fingered Bs., Choir Aahs, Vocal, Brass 1, and Bright Piano. The Tenor Sax, Baritone Sax, and Trumpet parts feature eighth-note patterns with accents. The Trombone part has a long, sustained note. The drummix part shows a complex rhythmic pattern with various drum sounds. The Steelstr. Gt. part consists of chords and single notes. The Fingered Bs. part has a melodic line. The Choir Aahs part has a sustained, harmonic texture. The Vocal part has the lyrics "thing on her mind" and a melodic line. The Brass 1 part has a sustained, harmonic texture. The Bright Piano part has a melodic line.

143

Alto Sax

Tenor Sax

Baritone Sax

Trumpet

Trombone

drummix

Steelstr. Gt.

Overdrive Gt.

Nylonstr. Gt.

Fingered Bs.

Choir Aahs

Vocal

Brass 1

Bright Piano

Ricky Martin - She Bangs 2

Alto Sax

♩ = 145,000031

9

13

17 32

52 2

58

63

67

72

78 12

94 2

2

Alto Sax

100

8

112

14

128

15

2

Ricky Martin - She Bangs 2

Tenor Sax

♩ = 145,000031

42 3

48 8

61

65

69 3

77 5

86 3 8

100 18

122 3 15

142 2

Baritone Sax

Ricky Martin - She Bangs 2

♩ = 145,000031

55 40

98

42

142

2

Ricky Martin - She Bangs 2

Trumpet

♩ = 145,000031

9

13

17 22

42

47 6

57

64 3

72

75 4

Trumpet

82

Musical staff for measures 82-86. The staff is in treble clef with a key signature of one sharp (F#). It contains five measures of music with various note values and rests.

87

Musical staff for measures 87-91. The staff is in treble clef with a key signature of one sharp (F#). It contains five measures of music, including a sixteenth-note triplet in measure 87.

92

Musical staff for measures 92-96. The staff is in treble clef with a key signature of one sharp (F#). It contains five measures, with measures 93 and 95 marked with a '7' and a '6' respectively, indicating a seven-measure and a six-measure rest.

109

Musical staff for measures 109-114. The staff is in treble clef with a key signature of one sharp (F#). It contains six measures, with measure 113 marked with a '2', indicating a two-measure rest.

115

Musical staff for measures 115-120. The staff is in treble clef with a key signature of one sharp (F#). It contains six measures, with a six-measure rest in measure 119.

121

Musical staff for measures 121-125. The staff is in treble clef with a key signature of one sharp (F#). It contains five measures of music.

126

Musical staff for measures 126-131. The staff is in treble clef with a key signature of one sharp (F#). It contains six measures, with a 14-measure rest in measure 131.

142

Musical staff for measures 142-146. The staff is in treble clef with a key signature of one sharp (F#). It contains five measures, with a 2-measure rest in measure 145.

Ricky Martin - She Bangs 2

Trombone

♩ = 145,000031

15 25

Musical staff for measures 15-25. Measure 15 is a whole rest. Measures 16-17 contain eighth notes: G#4, A4, B4, G#4, A4, B4. Measure 18 is a whole rest. Measure 19 is a whole note chord: G#4, A4, B4. Measure 20 is a whole rest. Measure 21 is a whole note chord: G#4, A4, B4. Measure 22 is a whole rest. Measure 23 is a whole note chord: G#4, A4, B4. Measure 24 is a whole rest. Measure 25 is a whole note chord: G#4, A4, B4.

43 3

Musical staff for measures 43-50. Measure 43: eighth notes G#4, A4, B4, G#4, A4, B4. Measure 44: eighth notes G#4, A4, B4, G#4, A4, B4. Measure 45: eighth notes G#4, A4, B4, G#4, A4, B4. Measure 46: eighth notes G#4, A4, B4, G#4, A4, B4. Measure 47: eighth notes G#4, A4, B4, G#4, A4, B4. Measure 48: eighth notes G#4, A4, B4, G#4, A4, B4. Measure 49: eighth notes G#4, A4, B4, G#4, A4, B4. Measure 50: eighth notes G#4, A4, B4, G#4, A4, B4.

50

Musical staff for measures 50-55. Measure 50: eighth notes G#4, A4, B4, G#4, A4, B4. Measure 51: eighth notes G#4, A4, B4, G#4, A4, B4. Measure 52: eighth notes G#4, A4, B4, G#4, A4, B4. Measure 53: eighth notes G#4, A4, B4, G#4, A4, B4. Measure 54: eighth notes G#4, A4, B4, G#4, A4, B4. Measure 55: eighth notes G#4, A4, B4, G#4, A4, B4.

55

Musical staff for measures 55-62. Measure 55: eighth notes G#4, A4, B4, G#4, A4, B4. Measure 56: eighth notes G#4, A4, B4, G#4, A4, B4. Measure 57: eighth notes G#4, A4, B4, G#4, A4, B4. Measure 58: eighth notes G#4, A4, B4, G#4, A4, B4. Measure 59: eighth notes G#4, A4, B4, G#4, A4, B4. Measure 60: eighth notes G#4, A4, B4, G#4, A4, B4. Measure 61: eighth notes G#4, A4, B4, G#4, A4, B4. Measure 62: eighth notes G#4, A4, B4, G#4, A4, B4.

62 12 9

Musical staff for measures 62-69. Measure 62: whole rest. Measure 63: whole rest. Measure 64: whole rest. Measure 65: whole rest. Measure 66: whole rest. Measure 67: whole rest. Measure 68: whole rest. Measure 69: whole rest.

86 3

Musical staff for measures 86-93. Measure 86: eighth notes G#4, A4, B4, G#4, A4, B4. Measure 87: eighth notes G#4, A4, B4, G#4, A4, B4. Measure 88: eighth notes G#4, A4, B4, G#4, A4, B4. Measure 89: eighth notes G#4, A4, B4, G#4, A4, B4. Measure 90: eighth notes G#4, A4, B4, G#4, A4, B4. Measure 91: eighth notes G#4, A4, B4, G#4, A4, B4. Measure 92: eighth notes G#4, A4, B4, G#4, A4, B4. Measure 93: eighth notes G#4, A4, B4, G#4, A4, B4.

93

Musical staff for measures 93-98. Measure 93: eighth notes G#4, A4, B4, G#4, A4, B4. Measure 94: eighth notes G#4, A4, B4, G#4, A4, B4. Measure 95: eighth notes G#4, A4, B4, G#4, A4, B4. Measure 96: eighth notes G#4, A4, B4, G#4, A4, B4. Measure 97: eighth notes G#4, A4, B4, G#4, A4, B4. Measure 98: eighth notes G#4, A4, B4, G#4, A4, B4.

98 11

Musical staff for measures 98-114. Measure 98: eighth notes G#4, A4, B4, G#4, A4, B4. Measure 99: eighth notes G#4, A4, B4, G#4, A4, B4. Measure 100: eighth notes G#4, A4, B4, G#4, A4, B4. Measure 101: eighth notes G#4, A4, B4, G#4, A4, B4. Measure 102: eighth notes G#4, A4, B4, G#4, A4, B4. Measure 103: eighth notes G#4, A4, B4, G#4, A4, B4. Measure 104: eighth notes G#4, A4, B4, G#4, A4, B4. Measure 105: eighth notes G#4, A4, B4, G#4, A4, B4. Measure 106: eighth notes G#4, A4, B4, G#4, A4, B4. Measure 107: eighth notes G#4, A4, B4, G#4, A4, B4. Measure 108: eighth notes G#4, A4, B4, G#4, A4, B4. Measure 109: eighth notes G#4, A4, B4, G#4, A4, B4. Measure 110: eighth notes G#4, A4, B4, G#4, A4, B4. Measure 111: eighth notes G#4, A4, B4, G#4, A4, B4. Measure 112: eighth notes G#4, A4, B4, G#4, A4, B4. Measure 113: eighth notes G#4, A4, B4, G#4, A4, B4. Measure 114: eighth notes G#4, A4, B4, G#4, A4, B4.

114 2

Musical staff for measures 114-120. Measure 114: whole rest. Measure 115: whole rest. Measure 116: whole rest. Measure 117: whole rest. Measure 118: whole rest. Measure 119: whole rest. Measure 120: whole rest.

120 3

Musical staff for measures 120-123. Measure 120: eighth notes G#4, A4, B4, G#4, A4, B4. Measure 121: eighth notes G#4, A4, B4, G#4, A4, B4. Measure 122: eighth notes G#4, A4, B4, G#4, A4, B4. Measure 123: eighth notes G#4, A4, B4, G#4, A4, B4.

125

Musical staff for measures 125-129. Measure 125 starts with a bass clef and a key signature of one flat. The melody begins with a quarter rest, followed by a quarter note G2, a quarter note F2, and a quarter note E2. Measure 126 has a quarter rest, a quarter note D2, and a quarter note C2. Measure 127 is a whole rest. Measure 128 contains a quarter rest, a quarter note B1, a quarter note A1, a quarter note G1, a quarter note F1, a quarter note E1, and a quarter note D1. Measure 129 ends with a quarter rest.

130

Musical staff for measures 130-133. Measure 130 continues the melody from measure 128. Measure 131 has a quarter rest, a quarter note C2, and a quarter note B1. Measure 132 has a quarter rest, a quarter note A1, and a quarter note G1. Measure 133 ends with a quarter rest.

134

Musical staff for measures 134-137. Measure 134 has a quarter rest, a quarter note F1, and a quarter note E1. Measure 135 is a whole rest. Measure 136 continues the melody from measure 128. Measure 137 ends with a quarter rest.

138

Musical staff for measures 138-140. Measure 138 continues the melody from measure 128. Measure 139 has a quarter rest, a quarter note B1, and a quarter note A1. Measure 140 ends with a quarter rest.

141

Musical staff for measures 141-143. Measure 141 has a quarter rest, a quarter note G1, and a quarter note F1. Measure 142 has a quarter rest, a quarter note E1, and a quarter note D1. Measure 143 is a whole rest. A large number '3' is positioned above the staff in measure 143, indicating a triplet or a section ending.

Ricky Martin - She Bangs 2

drummix

♩ = 145,000031

4

6

7

8

9

11

14

17

20

V.S.

23

26

29

32

35

38

41

44

47

50

53

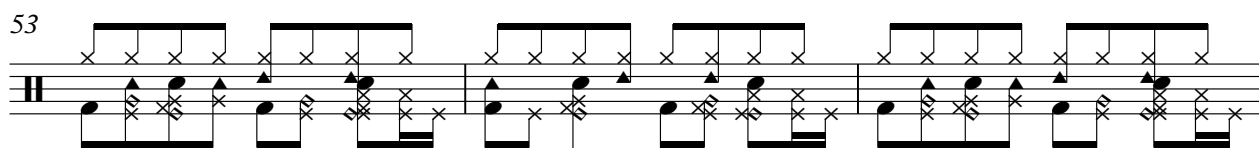

56

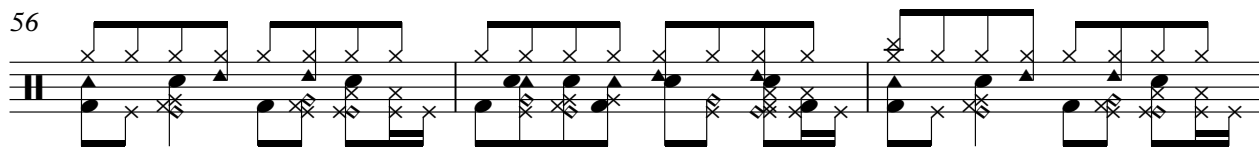

59

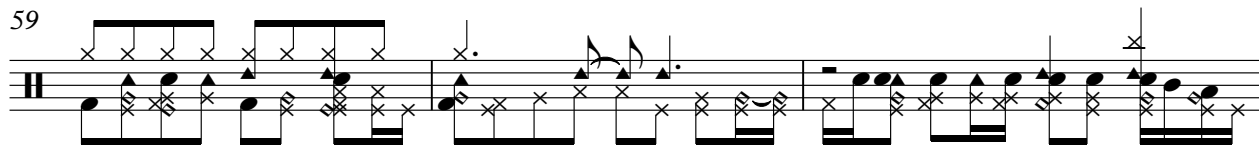

62

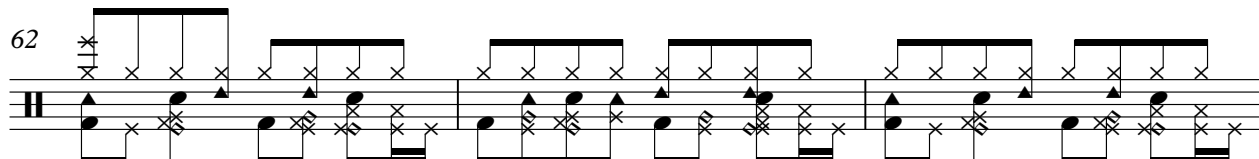

65

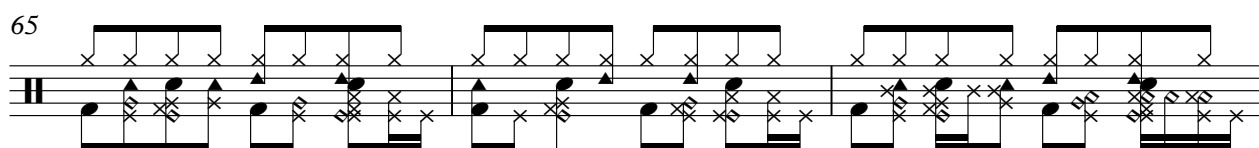

68

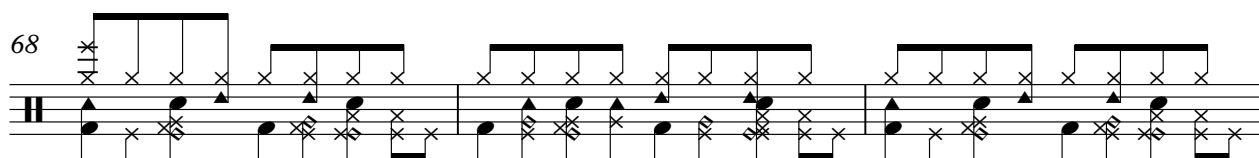

71

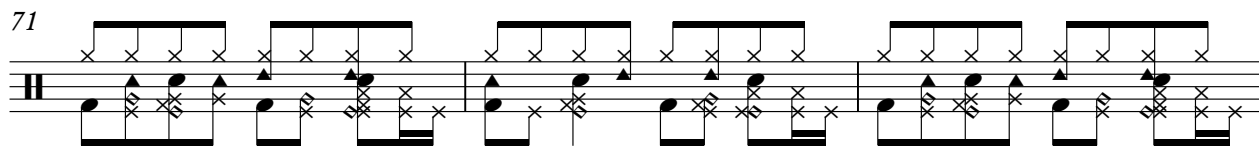

74



77

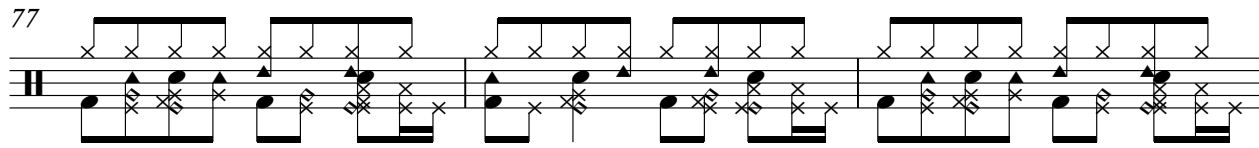

80

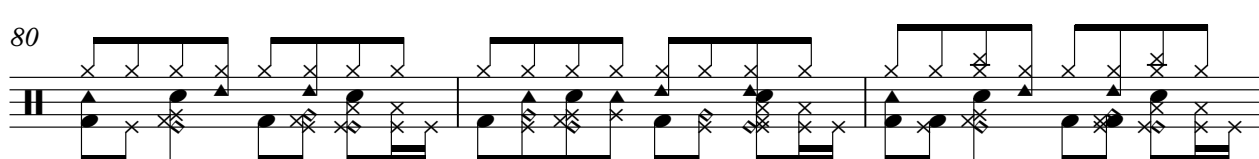

V.S.

83

Musical notation for measure 83, featuring a drum staff with various rhythmic patterns and a guitar staff with notes and fret markers.

86

Musical notation for measure 86, featuring a drum staff with various rhythmic patterns and a guitar staff with notes and fret markers.

89

Musical notation for measure 89, featuring a drum staff with various rhythmic patterns and a guitar staff with notes and fret markers.

92

Musical notation for measure 92, featuring a drum staff with various rhythmic patterns and a guitar staff with notes and fret markers.

95

Musical notation for measure 95, featuring a drum staff with various rhythmic patterns and a guitar staff with notes and fret markers.

98

Musical notation for measure 98, featuring a drum staff with various rhythmic patterns and a guitar staff with notes and fret markers.

101

Musical notation for measure 101, featuring a drum staff with various rhythmic patterns and a guitar staff with notes and fret markers.

104

Musical notation for measure 104, featuring a drum staff with various rhythmic patterns and a guitar staff with notes and fret markers.

107

Musical notation for measure 107, featuring a drum staff with various rhythmic patterns and a guitar staff with notes and fret markers.

110

Musical notation for measure 110, featuring a drum staff with various rhythmic patterns and a guitar staff with notes and fret markers.

113

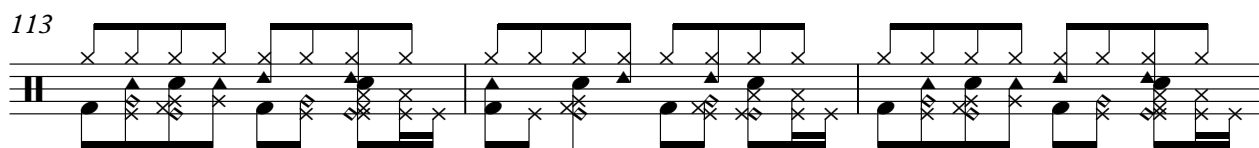

116

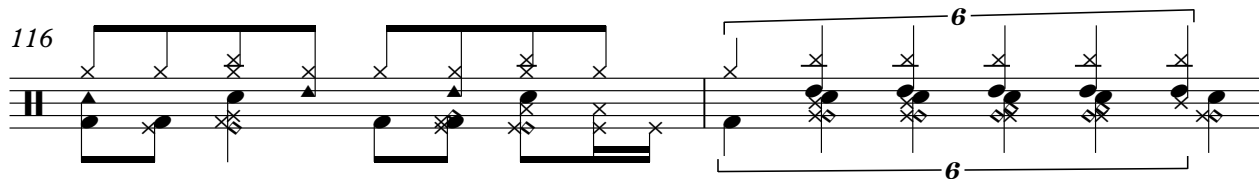

118

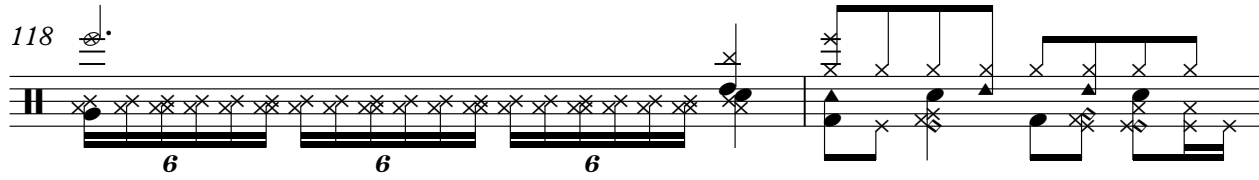

120

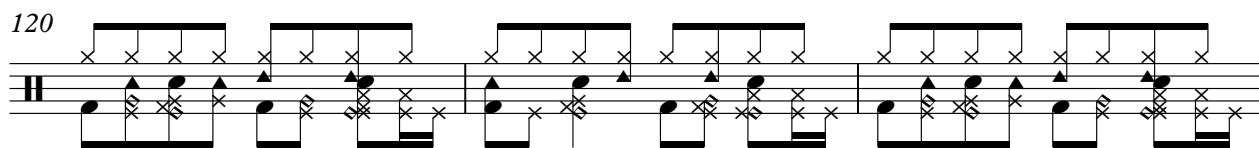

123

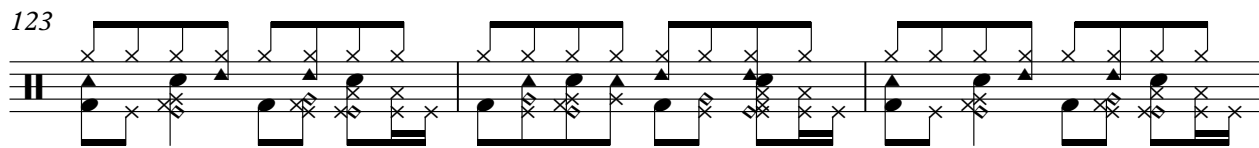

126

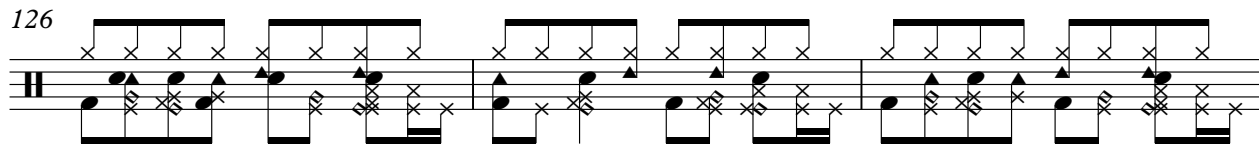

129

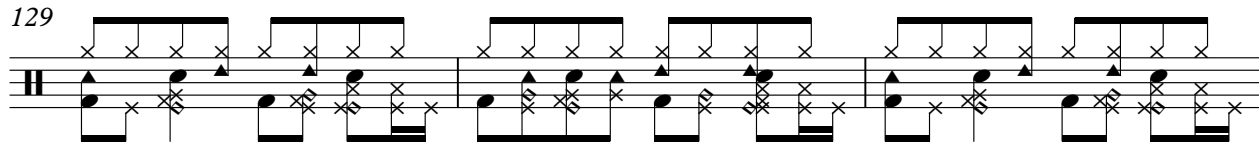

132

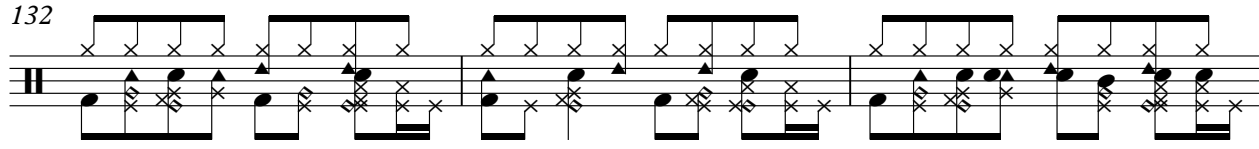

135

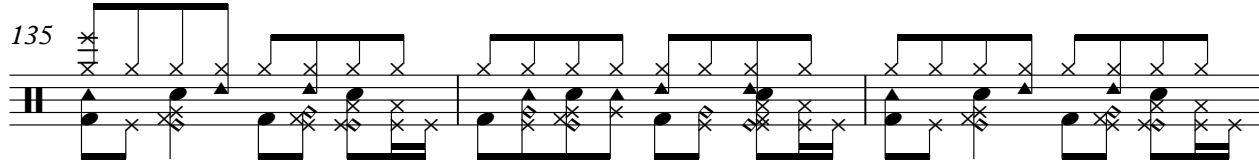

138

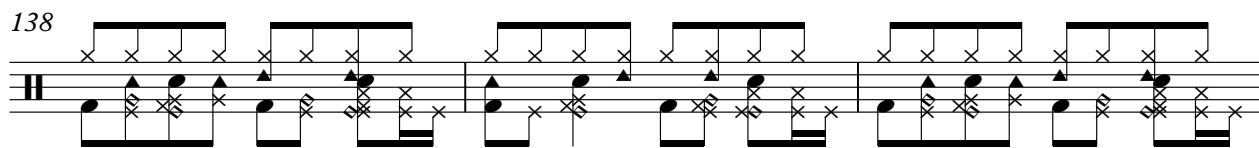

V.S.

6

drummix

141

Musical notation for measures 141 and 142. Measure 141 consists of two staves: the top staff has a series of 'x' marks indicating fretted notes, and the bottom staff has a rhythmic pattern of eighth notes. Measure 142 continues with similar notation, including a double bar line in the middle of the measure.

143

Musical notation for measure 143. The top staff shows a series of 'x' marks and a double bar line. The bottom staff shows a rhythmic pattern of eighth notes. A large number '2' is positioned above the second half of the measure, indicating a second ending or a specific rhythmic value.

Ricky Martin - She Bangs 2

Steelstr. Gt.

♩ = 145,000031

9

12

15

18

21

24

27

30

33

36

V.S.

39



42



45



48



51



54



57



64



67



70



73

76

79

82

85

88

91

94

97

100

103



106



109



112



115



119



122



125



128



131



134



137



140

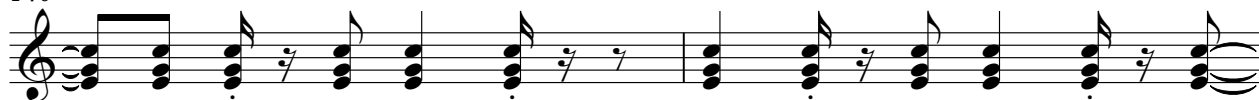

142

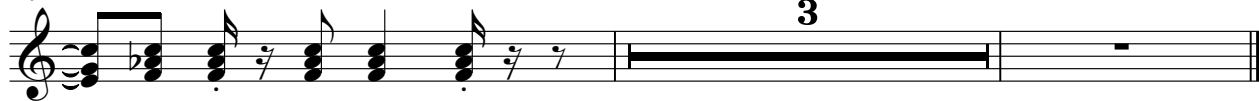

Ricky Martin - She Bangs 2

Overdrive Gt.

♩ = 145,000031

9 2

15 7

26 6

38 2

45 2

51

56 2 8

69 7 2

84

87 2

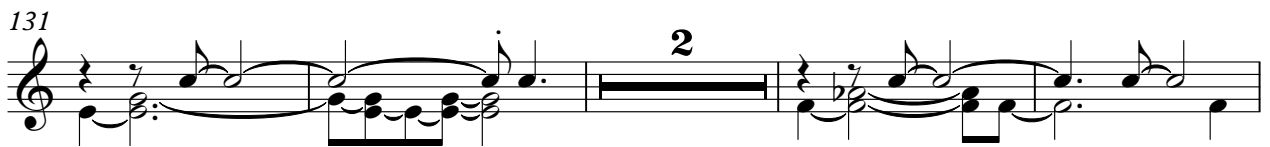
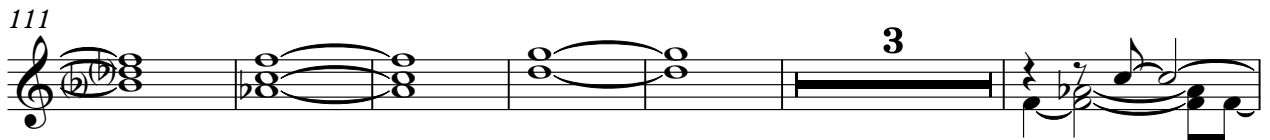
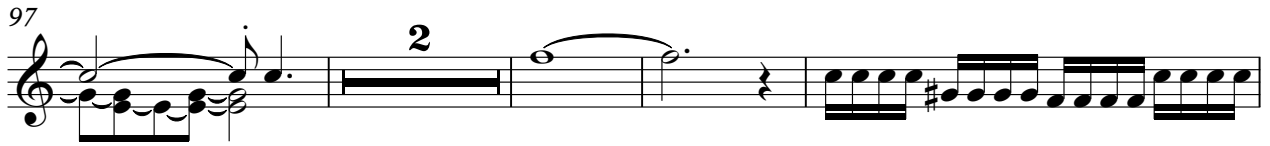

♩ = 145,000031

31

36

39

39

79

33

114

31

Ricky Martin - She Bangs 2

Fingered Bs.

♩ = 145,000031



V.S.

Fingered Bs.

42



46



50



54



59



65



69



73



77



80



83



87



91



95



99



103



107



111



114



116



119



123



127



131



135



139



142



Ricky Martin - She Bangs 2

Choir Aahs

♩ = 145,000031

17

23

27

33

37

41

45

48

52

60

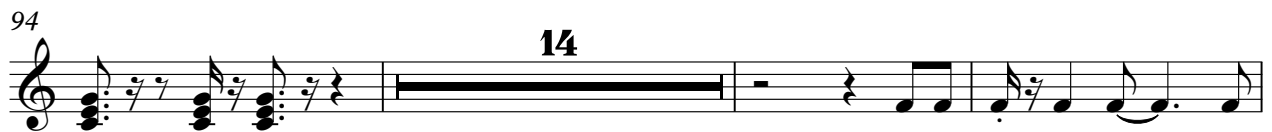
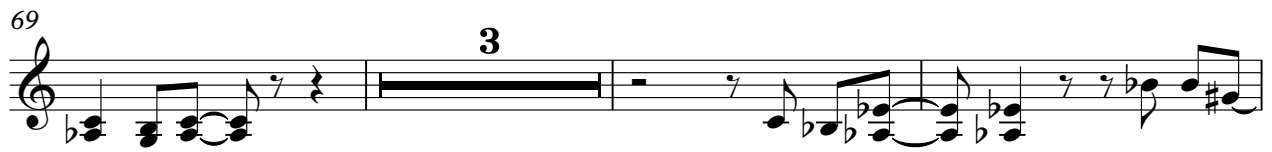

119



123



126



130



133



137



141



Ricky Martin - She Bangs 2

Vocal

♩ = 145,000031

(c) 2000 Musesymusic.com

14

Talk to me

19

Tell me your name You blow me off like it's all

21

the same You lit a fuse and now I'm

23

ti cking a way Like a bomb Ye ah, Ba by

V.S.

26 Vocal

Talk to me Tell me your sign You're switch ing sides like a

29

Ge mi ni You're playing games and now you're

31

hi ttin' my heart Like a drum Yeah, Ba by Well if

34

La dy Luck gets on my side We're gon na rock this town a live

37

I'll let her rough me up Till she knocks me out She

40

walks like she talks And she talks like she walks she bangs, she bangs

43 Vocal 3

Oh ba by shermoves, she moves I ,go cra zy 'Cause she

46

looks like a flower but she stings like a bee Like e very girl in

49

his to ry I'm was ted by the way shermoves No one

53

e ver look ed so fine She re minds me that

56

a wo man on ly got one thing on her mind

60

Talk to me Tell me your name I'm just a link in your dai

V.S.

63 Vocal

sy chain Your rap sounds like a dia mond Map to the

66

stars Ye ah, Ba by Talk to me Tell me the news

70

You wear me out like a pair of shoes We'll dance un til

73

the band goes ho me Then you're gone Yeah, Ba by Well if

76

it looks like loveshould be_a crime You'd be tter lock me up for life

79

I'll do the time with_a smile on my face Thin

82 Vocal 5

king of her in her lea ther and lace she bangs, she bangs

85

Oh ba by she moves, she moves I ,go cra zy 'Cause she

88

looks like a flower but she stings like a bee Like e very girl in

91

his to ry I'm was ted by the way she moves No one

95

e ver look ed so fine She re minds me that

98

a wo man on ly got one thing on her mind

V.S.

Vocal

103

Well if

110

La dy Luck gets on my side We're gon na rock this town a live

113

I'll let her rough me up Till she knocks me out She

116

walks like she talks And shetalks likeshowalks she bangs, she bangs

120

Oh ba by shemoves, she moves I ,go cra zy 'Cause she

123

looks like a flower but she stings like a bee Like e very girl in

126 Vocal 7

his to ry Oh ba by

130

I go cra zy 'Cause she looks like a flower but she stings like a bee

133

Like e very girl in his to ry I'm wasted

136

by the way she moves No one e ver look ed so

139

fine She re minds me that a wo man only got one

142

thing on her mind

Ricky Martin - She Bangs 2

Brass 1

♩ = 145,000031

8

11

14

17

21

40

44

48

52

56

59

4

Musical score for Brass 1, measures 66-113. The score is written in treble clef with a key signature of one flat (B-flat). The time signature is 4/4. The score consists of ten staves of music, each starting with a measure number. The notation includes various rhythmic values, accidentals, and dynamic markings. The first staff (66) features a complex rhythmic pattern with many rests. The second staff (72) has a similar pattern. The third staff (78) shows a more active melodic line. The fourth staff (82) continues with rhythmic complexity. The fifth staff (86) has a more melodic feel. The sixth staff (90) features a series of chords and rests. The seventh staff (94) has a melodic line with many accidentals. The eighth staff (98) includes a double bar line with a '2' above it, indicating a second ending. The ninth staff (106) also has a double bar line with a '2' above it. The tenth staff (113) concludes with a melodic line.

117 Brass 1 3

122

126

129

133

137

140

143 2

Ricky Martin - She Bangs 2

Bright Piano

$\text{♩} = 145,000031$
9

12
15
18
21
24
28
31
35
38

V.S.

Bright Piano

This musical score is for a piece titled "Bright Piano". It consists of 12 staves of music, with measure numbers 42, 45, 48, 52, 55, 62, 65, 69, 72, and 76 marked at the beginning of their respective staves. The music is written in a treble clef with a key signature of one sharp (F#). The tempo and dynamics are indicated as "Bright Piano". The score features a complex rhythmic pattern with frequent sixteenth and thirty-second notes, often beamed together. There are several rests and slurs throughout. A repeat sign with a first ending bracket is present at measure 55, with a "4" above it. The piece concludes at measure 76.

Bright Piano

This musical score consists of eight systems of music, each with a measure number on the left. The notation is for guitar, with a treble clef and a key signature of one flat (B-flat major or D minor). The piece is marked 'Bright Piano'. Measure 116 contains a '2' marking above the staff, indicating a second ending. The music features a mix of eighth and sixteenth notes, often beamed together, and rests. The final system, starting at measure 141, also includes a '2' marking above the staff, indicating a second ending that concludes with a double bar line.