

The Remains - Hang On Sloopy

♩ = 200,000000 ♩ = 118,002220
SLOOPY

This system of the musical score includes staves for Alto Saxophone, Percussion, three Electric Guitars, Electric Bass, Alto, and Tape Sampler Keyboard [Brass]. The tempo is marked as 200,000000 ♩ = 118,002220. The music is in 4/4 time. The Alto Saxophone and Alto staves are currently empty. The Percussion staff features a complex rhythmic pattern with many sixteenth notes. The Electric Guitars play a rhythmic accompaniment with eighth notes and chords. The Electric Bass line is a simple eighth-note pattern. The Tape Sampler Keyboard [Brass] staff is also empty.



6

This system of the musical score includes staves for Alto Sax., Perc., two E. Gtr., E. Bass, and Tape Smp. Brs. The music continues from the previous system. The Alto Sax. staff now has a melodic line starting with a half note G4. The Perc. staff continues with its rhythmic pattern. The E. Gtr. staves continue with their accompaniment. The E. Bass staff continues with its eighth-note pattern. The Tape Smp. Brs. staff has some chordal accompaniment.

9

Alto Sax.

Perc.

E. Gtr.

E. Gtr.

E. Bass

Tape Smp. Brs



12

Alto Sax.

Perc.

E. Gtr.

E. Gtr.

E. Bass

Tape Smp. Brs



15

Alto Sax.

Perc.

E. Gtr.

E. Gtr.

E. Bass

A.

18

Alto Sax.

Perc.

E. Gtr.

E. Gtr.

E. Bass

A.



21

Alto Sax.

Perc.

E. Gtr.

E. Gtr.

E. Bass

A.



24

Alto Sax.

Perc.

E. Gtr.

E. Gtr.

E. Bass

A.

27

Alto Sax.

Perc.

E. Gtr.

E. Gtr.

E. Bass

A.



30

Alto Sax.

Perc.

E. Gtr.

E. Gtr.

E. Bass

Tape Smp. Brs



33

Alto Sax.

Perc.

E. Gtr.

E. Gtr.

E. Bass

Tape Smp. Brs

36

Alto Sax.

Perc.

E. Gtr.

E. Gtr.

E. Gtr.

E. Bass

Tape Smp. Brs



38

Perc.

E. Gtr.

E. Gtr.

E. Gtr.

E. Bass



40

Perc.

E. Gtr.

E. Gtr.

E. Gtr.

E. Bass

42

Perc.

E. Gtr.

E. Gtr.

E. Gtr.

E. Bass



45

Perc.

E. Gtr.

E. Gtr.

E. Gtr.

E. Bass



48

Alto Sax.

Perc.

E. Gtr.

E. Gtr.

E. Bass



51

Alto Sax.

Perc.

E. Gtr.

E. Gtr.

E. Bass

A.

54

Alto Sax.

Perc.

E. Gtr.

E. Gtr.

E. Bass

A.



57

Alto Sax.

Perc.

E. Gtr.

E. Gtr.

E. Bass

A.



60

Alto Sax.

Perc.

E. Gtr.

E. Gtr.

E. Bass

63

Alto Sax.

Perc.

E. Gtr.

E. Gtr.

E. Bass



66

Alto Sax.

Perc.

E. Gtr.

E. Gtr.

E. Bass



69

Alto Sax.

Perc.

E. Gtr.

E. Gtr.

E. Bass



72

Alto Sax.

Perc.

E. Gtr.

E. Gtr.

E. Bass

75

Alto Sax.

Perc.

E. Gtr.

E. Gtr.

E. Bass

Tape Smp. Brs



78

Alto Sax.

Perc.

E. Gtr.

E. Gtr.

E. Bass

Tape Smp. Brs



81

Alto Sax.

Perc.

E. Gtr.

E. Gtr.

E. Bass

Tape Smp. Brs

$\text{♩} = 115,004219 \quad \text{♩} = 111,000114 \quad \text{♩} = 107,002419$

83 $\text{♩} = 111,000114$

Perc.



E. Gtr.

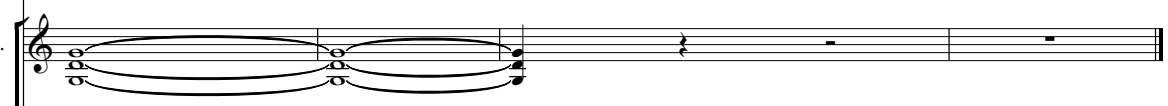

E. Gtr.

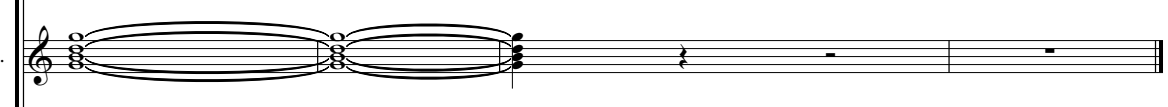

E. Bass



$\text{♩} = 111,000114$

Tape Smp. Brs



Detailed description: This page of a musical score, numbered 10, contains five staves. The top staff is for Percussion, starting at measure 83 with a tempo of 111,000114. It features a complex rhythmic pattern with triplets. The second and third staves are for Electric Guitar (E. Gtr.), both showing sustained chords. The fourth staff is for Electric Bass (E. Bass), showing sustained notes. The fifth staff is for Tape Sampler Brass (Tape Smp. Brs), also showing sustained notes. The tempo marking $\text{♩} = 111,000114$ is repeated at the bottom of the page.

The Remains - Hang On Sloopy

Alto Saxophone

♩ = 200,000000 ♩ = 118,002220

SLOOPY

2

8

14

18

22

26

30

35

13

50

Alto Saxophone

54



58



63



68



72



77



81

♩ = 1 5 2 4 2 0 0 2 0 0 1 1 4



The Remains - Hang On Sloopy

Percussion

♩ = 200,000000 ♩ = 118,002220

2

5

7

9

11

13

15

17

19

21

The image displays ten staves of percussion notation for the song 'Hang On Sloopy'. The notation is written on a five-line staff with a treble clef and a 4/4 time signature. The first staff begins with a 4/4 time signature and a tempo marking of ♩ = 200,000000. A second tempo marking, ♩ = 118,002220, is placed above the second measure. A large number '2' is positioned above the second measure. The notation consists of a series of rhythmic patterns, primarily using eighth and sixteenth notes, with various articulations such as accents and slurs. The notation is organized into measures, with some measures containing multiple rhythmic figures. The staves are numbered 2, 5, 7, 9, 11, 13, 15, 17, 19, and 21, indicating the measure number.

V.S.

23

Measure 23: A single staff of music with a treble clef and a double bar line. The staff contains a series of rhythmic patterns. The first half of the measure consists of four groups of notes, each starting with a cross symbol (x) above a quarter note, followed by a quarter note. The second half of the measure consists of four groups of notes, each starting with a triangle symbol (▲) above a quarter note, followed by a quarter note. The notes are primarily on the first and second lines of the staff.

25

Measure 25: Similar to measure 23, but with a more complex rhythmic pattern. The first half of the measure consists of four groups of notes, each starting with a cross symbol (x) above a quarter note, followed by a quarter note. The second half of the measure consists of four groups of notes, each starting with a triangle symbol (▲) above a quarter note, followed by a quarter note. The notes are primarily on the first and second lines of the staff.

27

Measure 27: Similar to measure 23, but with a more complex rhythmic pattern. The first half of the measure consists of four groups of notes, each starting with a cross symbol (x) above a quarter note, followed by a quarter note. The second half of the measure consists of four groups of notes, each starting with a triangle symbol (▲) above a quarter note, followed by a quarter note. The notes are primarily on the first and second lines of the staff.

29

Measure 29: Similar to measure 23, but with a more complex rhythmic pattern. The first half of the measure consists of four groups of notes, each starting with a cross symbol (x) above a quarter note, followed by a quarter note. The second half of the measure consists of four groups of notes, each starting with a triangle symbol (▲) above a quarter note, followed by a quarter note. The notes are primarily on the first and second lines of the staff.

31

Measure 31: Similar to measure 23, but with a more complex rhythmic pattern. The first half of the measure consists of four groups of notes, each starting with a cross symbol (x) above a quarter note, followed by a quarter note. The second half of the measure consists of four groups of notes, each starting with a triangle symbol (▲) above a quarter note, followed by a quarter note. The notes are primarily on the first and second lines of the staff.

33

Measure 33: Similar to measure 23, but with a more complex rhythmic pattern. The first half of the measure consists of four groups of notes, each starting with a cross symbol (x) above a quarter note, followed by a quarter note. The second half of the measure consists of four groups of notes, each starting with a triangle symbol (▲) above a quarter note, followed by a quarter note. The notes are primarily on the first and second lines of the staff.

35

Measure 35: Similar to measure 23, but with a more complex rhythmic pattern. The first half of the measure consists of four groups of notes, each starting with a cross symbol (x) above a quarter note, followed by a quarter note. The second half of the measure consists of four groups of notes, each starting with a triangle symbol (▲) above a quarter note, followed by a quarter note. The notes are primarily on the first and second lines of the staff.

37

Measure 37: Similar to measure 23, but with a more complex rhythmic pattern. The first half of the measure consists of four groups of notes, each starting with a cross symbol (x) above a quarter note, followed by a quarter note. The second half of the measure consists of four groups of notes, each starting with a triangle symbol (▲) above a quarter note, followed by a quarter note. The notes are primarily on the first and second lines of the staff.

39

Measure 39: Similar to measure 23, but with a more complex rhythmic pattern. The first half of the measure consists of four groups of notes, each starting with a cross symbol (x) above a quarter note, followed by a quarter note. The second half of the measure consists of four groups of notes, each starting with a triangle symbol (▲) above a quarter note, followed by a quarter note. The notes are primarily on the first and second lines of the staff.

41

Measure 41: Similar to measure 23, but with a more complex rhythmic pattern. The first half of the measure consists of four groups of notes, each starting with a cross symbol (x) above a quarter note, followed by a quarter note. The second half of the measure consists of four groups of notes, each starting with a triangle symbol (▲) above a quarter note, followed by a quarter note. The notes are primarily on the first and second lines of the staff.

43

Musical notation for measure 43, featuring a complex rhythmic pattern with eighth and sixteenth notes, rests, and accents on a five-line staff.

45

Musical notation for measure 45, continuing the rhythmic pattern with eighth and sixteenth notes, rests, and accents on a five-line staff.

47

Musical notation for measure 47, continuing the rhythmic pattern with eighth and sixteenth notes, rests, and accents on a five-line staff.

49

Musical notation for measure 49, continuing the rhythmic pattern with eighth and sixteenth notes, rests, and accents on a five-line staff.

51

Musical notation for measure 51, continuing the rhythmic pattern with eighth and sixteenth notes, rests, and accents on a five-line staff.

53

Musical notation for measure 53, continuing the rhythmic pattern with eighth and sixteenth notes, rests, and accents on a five-line staff.

55

Musical notation for measure 55, continuing the rhythmic pattern with eighth and sixteenth notes, rests, and accents on a five-line staff.

57

Musical notation for measure 57, continuing the rhythmic pattern with eighth and sixteenth notes, rests, and accents on a five-line staff.

59

Musical notation for measure 59, continuing the rhythmic pattern with eighth and sixteenth notes, rests, and accents on a five-line staff.

61

Musical notation for measure 61, continuing the rhythmic pattern with eighth and sixteenth notes, rests, and accents on a five-line staff.

V.S.

63

65

67

69

71

73

75

77

79

81

$\text{♩} = 115,0042 \text{ } \#9111,000114 \text{ } \text{♩} = 107,002419$

The image displays ten staves of musical notation for a percussion instrument, numbered 63 through 81. Each staff begins with a double bar line and a vertical line, indicating the instrument's position. The notation consists of rhythmic patterns of eighth and sixteenth notes, often grouped with beams and slurs. Above the notes, there are 'x' marks and arrows, which are standard notation for indicating specific drum hits or techniques. The notation is arranged in a continuous sequence across the staves. At the end of the eighth staff (measure 81), there are two tempo markings: $\text{♩} = 115,0042 \text{ } \#9111,000114 \text{ } \text{♩} = 107,002419$.

83 ♩ = 111,000114

Percussion

Musical notation for Percussion on a five-line staff. The notation includes a treble clef, a key signature of one flat, and a 4/4 time signature. The first measure contains a quarter note with a grace note, a dotted quarter note, and an eighth note. The second measure is a whole rest. The third measure contains a quarter note with a grace note, a dotted quarter note, and an eighth note, with a triplet bracket over the last two notes. The fourth measure is a whole rest. The fifth measure contains a quarter note with a grace note, a dotted quarter note, and an eighth note, with a triplet bracket under the last two notes. The sixth measure is a whole rest. The piece ends with a double bar line.

The Remains - Hang On Sloopy

Electric Guitar

♩ = 200,000000 ♩ = 118,002220

2

5

7

9

11

13

15

17

19

21

V.S.

23



25



27



29



31



33



35



37



39



41



43



45



47



49



51



53



55



57



59



61



V.S.

63



65



67



69



71



73



75



77



79



81

♩ = 115,000 119,000 114 = 107,000 100,000 114



85

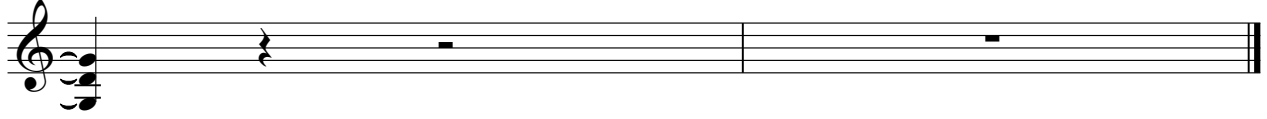

Electric Guitar

The Remains - Hang On Sloopy

♩ = 200,000000 ♩ = 118,002220

2 31

A musical staff in 4/4 time with two measures. The first measure is marked with a '2' and the second with a '31'. Both measures contain a solid black bar, indicating a full-measure rest.

38

3 3 6 6 6 3

A musical staff starting at measure 38. It contains six measures of music. The first measure has a triplet of eighth notes. The second and third measures have eighth-note triplets. The fourth, fifth, and sixth measures have sixteenth-note triplets. The staff ends with a double bar line.

40

6 6 3

A musical staff starting at measure 40. It contains four measures of music. The first two measures have sixteenth-note triplets. The third measure has a triplet of eighth notes. The fourth measure has a triplet of eighth notes. The staff ends with a double bar line.

43

A musical staff starting at measure 43. It contains four measures of music. The first measure has a dotted quarter note followed by an eighth note. The second measure has a quarter note followed by an eighth note. The third and fourth measures have eighth-note triplets. The staff ends with a double bar line.

46

35 2

A musical staff starting at measure 46. It contains three measures. The first measure is marked with a '35' and the second with a '2'. Both measures contain a solid black bar, indicating a full-measure rest.

85

2

A musical staff starting at measure 85. It contains one measure marked with a '2', which is a solid black bar indicating a full-measure rest. The staff ends with a double bar line.

The Remains - Hang On Sloopy

Electric Guitar

♩ = 200,000000 ♩ = 118,002220

2

6

11

16

21

26

31

36

41

46

V.S.

51

56

61

66

71

76

80

♩ = 1 1 5 0 0 4 2, 0 0 0 # 1 4 0 7, 0 0 2 4, 0 0 0 1 1 4

85

The Remains - Hang On Sloopy

Electric Bass

♩ = 200,000000 ♩ = 118,002220



V.S.

41



45



49



53



57



61



65



69



72



75



79



82

♩ = 115,0042119,000107,0024119,000114



The Remains - Hang On Sloopy

Alto

♩ = 200,000000 ♩ = 118,002220

2 9

17

2 2

26

2 22

54

2

59

♩ = 115,0011210510024090114

23 2

85

2

Tape Sampler Keyboard [Brass] The Remains - Hang On Sloopy

♪ = 200,000000 ♩ = 118,002220

Musical notation for measures 1-5. The piece is in 4/4 time. Measures 1-5 are marked with a '2' above the staff, indicating a two-measure rest. The bass line begins in measure 5 with a series of chords: G2, D2, F2, C2, G2, D2, F2, C2.

Musical notation for measures 6-8. Measure 6 contains a melodic line in the treble clef: G4, A4, B4, C5, B4, A4, G4. Measures 7-8 are marked with a '2' above the staff, indicating a two-measure rest. The bass line continues with chords: G2, D2, F2, C2, G2, D2, F2, C2.

Musical notation for measures 9-12. Measures 9-12 are marked with an '18' above the staff, indicating an 18-measure rest. The bass line continues with chords: G2, D2, F2, C2, G2, D2, F2, C2.

Musical notation for measures 13-16. Measure 13 contains a melodic line in the treble clef: G4, A4, B4, C5, B4, A4, G4. Measures 14-16 are marked with a '2' above the staff, indicating a two-measure rest. The bass line continues with chords: G2, D2, F2, C2, G2, D2, F2, C2.

Musical notation for measures 17-36. Measure 17 contains a melodic line in the treble clef: G4, A4, B4, C5, B4, A4, G4. Measures 18-36 are marked with a '39' above the staff, indicating a 39-measure rest.

Musical notation for measures 37-40. Measure 37 contains a melodic line in the treble clef: G4, A4, B4, C5, B4, A4, G4. Measures 38-40 are marked with a '2' above the staff, indicating a two-measure rest. The bass line continues with chords: G2, D2, F2, C2, G2, D2, F2, C2.

2

Tape Sampler Keyboard [Brass]

♩ = 115,004 219,000 107,002 419 = 111,000114

81

Musical notation for measures 81-84. Measure 81: Bass clef, two chords (F major and C major) with eighth notes. Measure 82: Treble clef, four chords (F major, C major, F major, C major) with eighth notes. Measure 83: Bass clef, two chords (F major and C major) with eighth notes. Measure 84: Treble clef, two chords (F major and C major) with eighth notes.

85

Musical notation for measures 85-88. Measure 85: Bass clef, one chord (F major) with eighth notes. Measure 86: Treble clef, one chord (F major) with eighth notes. Measure 87: Bass clef, one chord (F major) with eighth notes. Measure 88: Treble clef, one chord (F major) with eighth notes.