

Cranberries - Twenty One

♩ = 117,999901

Dolores

Drum

Distorsion

Guitare 1

Guitare 2

Basse

Aahs

Dolores 2

Halo

Crystal

♩ = 117,999901

Strings



6

Drum

Guitare 1

Guitare 2

Basse

Crystal

10

Dolores
Drum
Guitare 1
Guitare 2
Basse
Dolores 2
Crystal
Strings

This musical score covers measures 10 through 13. It features seven staves: Dolores (melody), Drum (rhythm), Guitare 1 (lead), Guitare 2 (chords), Basse (bass line), Dolores 2 (second melody), Crystal (second lead), and Strings (background). The key signature has two flats (B-flat and E-flat), and the time signature is 4/4. The score includes various musical notations such as eighth notes, quarter notes, and chords.



14

Dolores
Drum
Guitare 1
Guitare 2
Basse
Dolores 2
Crystal
Strings

This musical score covers measures 14 through 17. It features the same seven staves as the previous section: Dolores (melody), Drum (rhythm), Guitare 1 (lead), Guitare 2 (chords), Basse (bass line), Dolores 2 (second melody), Crystal (second lead), and Strings (background). The key signature and time signature remain consistent with the previous section. The score continues with similar musical notations.

18

Dolores

Drum

Guitare 1

Guitare 2

Basse

Dolores 2

Crystal

Strings



22

Dolores

Drum

Guitare 1

Guitare 2

Basse

Dolores 2

Crystal

Strings

26

Dolores
Drum
Guitare 1
Guitare 2
Basse
Dolores 2
Crystal
Strings



30

Dolores
Drum
Guitare 1
Guitare 2
Basse
Dolores 2
Crystal
Strings

34

Dolores
Drum
Distorsion
Guitare 1
Guitare 2
Basse
Aahs
Dolores 2
Halo
Crystal
Strings



39

Dolores
Drum
Distorsion
Guitare 1
Guitare 2
Basse
Dolores 2
Crystal
Strings

43

Dolores
Drum
Guitare 1
Guitare 2
Basse
Dolores 2
Crystal
Strings

This musical system covers measures 43 to 46. It features seven staves: Dolores (melody), Drum (percussion), Guitare 1 (lead guitar), Guitare 2 (rhythm guitar), Basse (bass), Dolores 2 (second melody), and Strings. The key signature has one flat (B-flat), and the time signature is 4/4. The Dolores part has a melodic line with some rests. The Drum part has a consistent rhythmic pattern. Guitare 1 has a lead line with bends and slurs. Guitare 2 has a complex chordal texture. The Basse part has a simple bass line. Dolores 2 has a melodic line with some rests. The Crystal part has a melodic line similar to Dolores. The Strings part has a simple chordal accompaniment.



47

Dolores
Drum
Guitare 1
Guitare 2
Basse
Dolores 2
Crystal
Strings

This musical system covers measures 47 to 50. It features the same seven staves as the previous system. The key signature and time signature remain the same. The Dolores part has a melodic line with some rests. The Drum part has a consistent rhythmic pattern. Guitare 1 has a lead line with bends and slurs. Guitare 2 has a complex chordal texture. The Basse part has a simple bass line. Dolores 2 has a melodic line with some rests. The Crystal part has a melodic line similar to Dolores. The Strings part has a simple chordal accompaniment.

51 $\text{♩} = 116,000084$ 7

Dolores

Drum

Guitare 1

Guitare 2

Basse

Aahs

Dolores 2

Crystal

Strings $\text{♩} = 116,000084$



55 $\text{♩} = 117,999901$ $\text{♩} = 116,000084$

Dolores

Drum

Guitare 1

Guitare 2

Basse

Aahs

Dolores 2

Crystal

Strings $\text{♩} = 117,999901$ $\text{♩} = 116,000084$

59 ♩ = 117,999901

Dolores

Drum

Distorsion

Guitare 1

Guitare 2

Basse

Aahs

Dolores 2

Halo

Crystal

♩ = 117,999901

Strings

Detailed description: This is a musical score for a multi-instrument ensemble. The score is written for 11 parts: Dolores (vocals), Drum (percussion), Distorsion (effects), Guitare 1 (electric guitar), Guitare 2 (electric guitar), Basse (bass), Aahs (vocals), Dolores 2 (vocals), Halo (strings), Crystal (strings), and Strings (strings). The tempo is marked as ♩ = 117,999901. The score is divided into two systems. The first system contains Dolores, Drum, Distorsion, Guitare 1, Guitare 2, Basse, Aahs, Dolores 2, and Halo. The second system contains Crystal and Strings. The music is written in a key with one flat (B-flat major or D minor) and a 4/4 time signature. The Dolores parts feature melodic lines with various rhythmic patterns. The Drum part has a complex, syncopated pattern. The Guitare 1 part has a melodic line with bends. The Guitare 2 part has a dense, rhythmic accompaniment. The Basse part has a steady, rhythmic line. The Aahs part has a melodic line with a long note. The Dolores 2 part has a melodic line with a long note. The Halo part has a sustained, harmonic line. The Crystal part has a melodic line with bends. The Strings part has a sustained, harmonic line.

64

Dolores

Drum

Distorsion

Guitare 1

Guitare 2

Basse

Aahs

Dolores 2

Halo

Crystal

Strings

Detailed description: This is a multi-staff musical score for a rock band. The score is divided into ten parts: Dolores (vocals), Drum (percussion), Distorsion (effects), Guitare 1 (lead guitar), Guitare 2 (rhythm guitar), Basse (bass), Aahs (vocals), Dolores 2 (vocals), Halo (strings), Crystal (strings), and Strings (strings). The score begins at measure 64. The Dolores part has a melodic line with a final flourish. The Drum part features a complex, syncopated rhythm with various drum sounds indicated by 'x' marks. The Distorsion part is mostly silent. Guitare 1 plays a rhythmic pattern with a 7th fret bend. Guitare 2 plays a heavy, distorted chord progression with a triplet. The Basse part provides a steady bass line. Aahs has a vocal line with a 'u' mark. Dolores 2 has a vocal line with a final flourish. Halo plays a sustained, heavy chord. Crystal plays a rhythmic pattern with a 7th fret bend. The Strings part plays a sustained, heavy chord.

68

Dolores
Drum
Guitare 1
Guitare 2
Basse
Aahs
Dolores 2
Halo
Crystal
Strings

Detailed description: This system contains measures 68 through 71. It features ten staves: Dolores (vocals), Drum (percussion), Guitare 1 (lead guitar), Guitare 2 (rhythm guitar), Basse (bass), Aahs (vocals), Dolores 2 (vocals), Halo (vocals), Crystal (vocals), and Strings (orchestra). The music is in a key with one flat and a 4/4 time signature. The guitar parts are complex, with Guitare 2 featuring heavy chordal textures and Guitare 1 playing a melodic line. The vocal parts are sparse, with Dolores and Dolores 2 having long rests.

72

Dolores
Drum
Guitare 1
Guitare 2
Basse
Aahs
Dolores 2
Halo
Crystal
Strings

Detailed description: This system contains measures 72 through 75. It features the same ten staves as the previous system. The musical notation continues, with similar instrumental textures and vocal parts. The structure and instrumentation remain consistent with the first system.

76

Dolores

Drum

Guitare 1

Guitare 2

Basse

Aahs

Dolores 2

Halo

Crystal

Strings

80

Dolores

Drum

Guitare 1

Guitare 2

Basse

Aahs

Dolores 2

Halo

Crystal

Strings

84

Dolores

Drum

Guitare 1

Guitare 2

Basse

Aahs

Dolores 2

Halo

Crystal

Strings



88

Dolores

Drum

Guitare 1

Guitare 2

Basse

Dolores 2

Crystal

Strings

91

Drum



Guitare 1



Guitare 2



Basse



Crystal



Cranberries - Twenty One

Dolores

♩ = 117,999901

8

13

17

21

26

30

4

38

42

46

51

♩ = 116,000084 ♩ = 117,999901

V.S.

2

Dolores

♩ = 116,000084

♩ = 117,999901

56



60

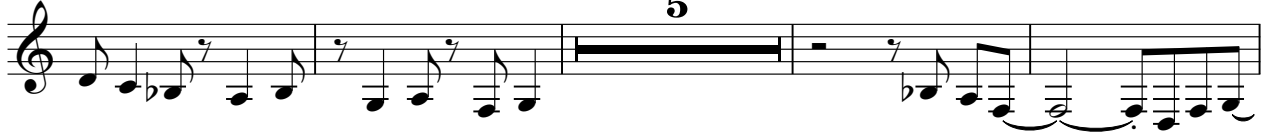

69



75



80



85



88



Cranberries - Twenty One

Drum

♩ = 117,999901

Drum notation for measures 1-4. Measure 1 is in 2/4 time and contains a whole rest. Measure 2 is in 4/4 time and contains a continuous eighth-note pattern. Measures 3 and 4 continue the eighth-note pattern with occasional 'x' marks indicating cymbal hits.

4

Drum notation for measures 5-8. Measures 5 and 6 continue the eighth-note pattern. Measures 7 and 8 introduce a more complex pattern with eighth notes and 'x' marks.

7

Drum notation for measures 9-12. Measures 9 and 10 continue the eighth-note pattern. Measures 11 and 12 introduce a more complex pattern with eighth notes and 'x' marks.

10

Drum notation for measures 13-16. Measures 13 and 14 continue the eighth-note pattern. Measures 15 and 16 introduce a more complex pattern with eighth notes and 'x' marks.

13

Drum notation for measures 17-20. Measures 17 and 18 continue the eighth-note pattern. Measures 19 and 20 introduce a more complex pattern with eighth notes and 'x' marks.

16

Drum notation for measures 21-24. Measures 21 and 22 continue the eighth-note pattern. Measures 23 and 24 introduce a more complex pattern with eighth notes and 'x' marks.

19

Drum notation for measures 25-28. Measures 25 and 26 continue the eighth-note pattern. Measures 27 and 28 introduce a more complex pattern with eighth notes and 'x' marks.

22

Drum notation for measures 29-32. Measures 29 and 30 continue the eighth-note pattern. Measures 31 and 32 introduce a more complex pattern with eighth notes and 'x' marks.

25

Drum notation for measures 33-36. Measures 33 and 34 continue the eighth-note pattern. Measures 35 and 36 introduce a more complex pattern with eighth notes and 'x' marks.

28

Drum notation for measures 37-40. Measures 37 and 38 continue the eighth-note pattern. Measures 39 and 40 introduce a more complex pattern with eighth notes and 'x' marks.

V.S.

Drum

31

34

37

40

43

46

49

52

55

58

Tempo markings: ♩ = 116,000084 and ♩ = 117,999901

Drum

61

64

67

70

73

76

79

82

85

88

4

Drum

91

The image shows a drum notation staff with five lines. The notation is as follows:
- Measure 1: A double bar line on the left. Above the staff, there are four 'x' marks with stems pointing down, followed by an asterisk with a stem pointing down. Below the staff, there are four 'x' marks with stems pointing down, followed by a solid black dot with a stem pointing down.
- Measure 2: Above the staff, there are four 'x' marks with stems pointing down, followed by an asterisk with a stem pointing down. Below the staff, there are four 'x' marks with stems pointing down, followed by a solid black dot with a stem pointing down.
- Measure 3: Above the staff, there is a circled 'S' with a slash through it. Below the staff, there is a circled 'S' with a slash through it.
- Measure 4: A double bar line on the right. Above the staff, there is a large number '2'. Below the staff, there is a thick black horizontal bar spanning the width of the measure.

Distorsion

Cranberries - Twenty One

♩ = 117,999901

32

A musical staff in treble clef with a 2/4 time signature. The first measure contains a whole rest. The second measure contains a 32-measure rest, indicated by a thick black bar and the number 32 above it. The staff continues with a series of notes: a half note, a quarter note, a quarter note, a half note, and a whole note, all connected by a slur.

39

15

♩ = 116,000084 = 117,999901 ♩ = 116,000084 = 117,999901

3

3

A musical staff in treble clef. The first measure contains a 15-measure rest, indicated by a thick black bar and the number 15 above it. The second measure contains a whole rest. The third measure contains a 3-measure rest, indicated by a thick black bar and the number 3 above it. The fourth measure contains a whole rest. The fifth measure contains a 3-measure rest, indicated by a thick black bar and the number 3 above it. Above the staff, there are four quarter notes with the following durations: ♩ = 116,000084, ♩ = 117,999901, ♩ = 116,000084, and ♩ = 117,999901.

62

30

A musical staff in treble clef. The first three measures contain a series of notes: a half note, a quarter note, and a quarter note, all connected by a slur. The fourth measure contains a whole note. The fifth measure contains a 30-measure rest, indicated by a thick black bar and the number 30 above it.

Guitare 1

Cranberries - Twenty One

♩ = 117,999901

The musical score is written on a single treble clef staff. It begins with a 2/4 time signature, which changes to 4/4 after the first measure. The key signature has one flat (B-flat). The tempo is marked as ♩ = 117,999901. The score consists of ten lines of music, with measure numbers 6, 10, 14, 18, 22, 26, 30, and 32 indicated at the start of their respective lines. The melody is primarily composed of eighth and quarter notes, often beamed together. The final line of music (measures 32-35) ends with a double bar line and a '4' above it, indicating a four-measure rest.

38

42

46

50

54 ♩ = 116,000084 ♩ = 117,999901

58 ♩ = 116,000084 ♩ = 117,999901

62

4

69

73

77

81



85



89



92



Guitare 2

Cranberries - Twenty One

♩ = 117,999901

6

9

12

15

18

21

24

27

30

V.S.

33

3

39

42

45

48

51

54

♩ = 116,00084

♩ = 117,999901

57

♩ = 116,00084

♩ = 117,999901

60

66

Guitare 2

3

69

72

75

78

81

84

87

90



Cranberries - Twenty One

Basse

♩ = 117,999901



7



13



19



25



31



37



42



48



53

♩ = 116,000084 ♩ = 117,999901



V.S.

2

Basse

58 ♩ = 116,000084 = 117,999901

64

70

76

81

87

91

Cranberries - Twenty One

Aahs

The musical score is written in treble clef and 4/4 time. It begins with a tempo marking of ♩ = 117,999901. The first system shows a 32-measure rest followed by a melodic line starting on a whole note G4. The second system starts at measure 38 with a 16-measure rest, then continues with a melodic line in a key signature of one flat (Bb), featuring eighth notes and chords. The third system starts at measure 57 with a tempo change to ♩ = 116,000084, followed by a return to the original tempo of ♩ = 117,999901. The fourth system starts at measure 62 with a melodic line. The fifth system starts at measure 68 with a melodic line. The sixth system starts at measure 73 with a melodic line. The seventh system starts at measure 79 with a melodic line. The eighth system starts at measure 83 with a melodic line and ends with a 10-measure rest.

♩ = 117,999901

8

13

18

23

27

31

4

39

44

49

54 ♩ = 116,000084 ♩ = 117,999901

2

Dolores 2

58 ♩ = 116,000084 ♩ = 117,999901



67

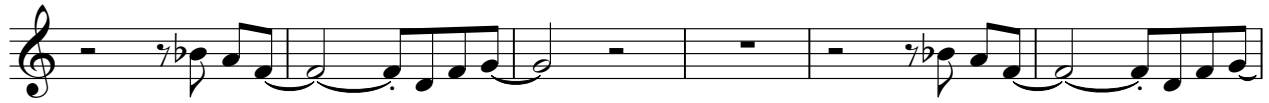

73



79



84



88



Cranberries - Twenty One

Halo

♩ = 117,999901

32



38

♩ = 116,000084 ♩ = 116,000084 ♩ = 116,000084 ♩ = 117,999901

16 3 2

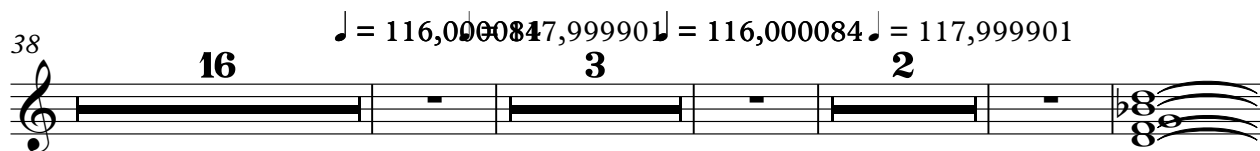

63



69

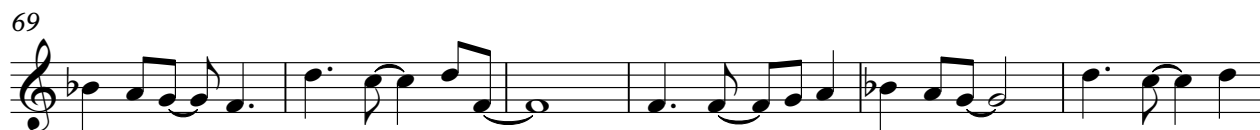

75



81



84

10



♩ = 117,999901

6

10

14

18

22

26

30

32

4



83



87



90



Cranberries - Twenty One

Strings

♩ = 117,999901

Musical staff 1: Bass clef, 2/4 time signature, followed by a 4/4 time signature. A bar with a fermata and the number '8' above it spans the first two measures of the 4/4 section. The staff contains several chords with flats.

Musical staff 2: Bass clef, 4/4 time signature. The staff contains several chords with flats.

Musical staff 3: Bass clef, 4/4 time signature. The staff contains several chords with flats.

Musical staff 4: Bass clef, 4/4 time signature. The first four measures feature a melodic line with slurs and ties, followed by chords with flats.

Musical staff 5: Bass clef, 4/4 time signature. The staff contains several chords with flats.

Musical staff 6: Bass clef, 4/4 time signature. Above the staff, there are two tempo markings: ♩ = 116,0000847,999901 and ♩ = 116,0000847,999901. The staff contains several chords with flats.

Musical staff 7: Bass clef, 4/4 time signature. The first four measures feature a melodic line with slurs and ties, followed by chords with flats.

Musical staff 8: Bass clef, 4/4 time signature. The staff contains several chords with flats.

Musical staff 9: Bass clef, 4/4 time signature. The staff contains several chords with flats.

Musical staff 10: Bass clef, 4/4 time signature. The staff contains several chords with flats, followed by a bar with a fermata and the number '6' above it.